

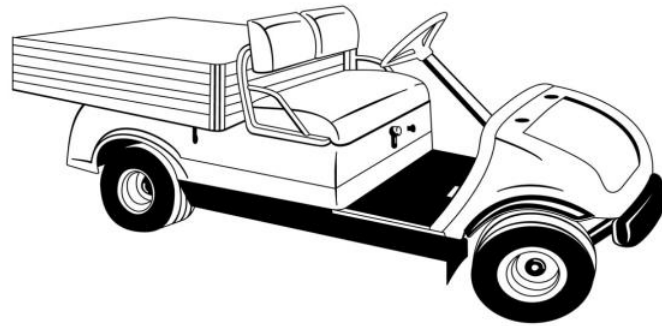

PARTS CATALOG



2004 G21AZ

(JR61) U.S.A., CANADA, EUROPE, OTHERS

OCTOBER 2003

1CJR6-100E1

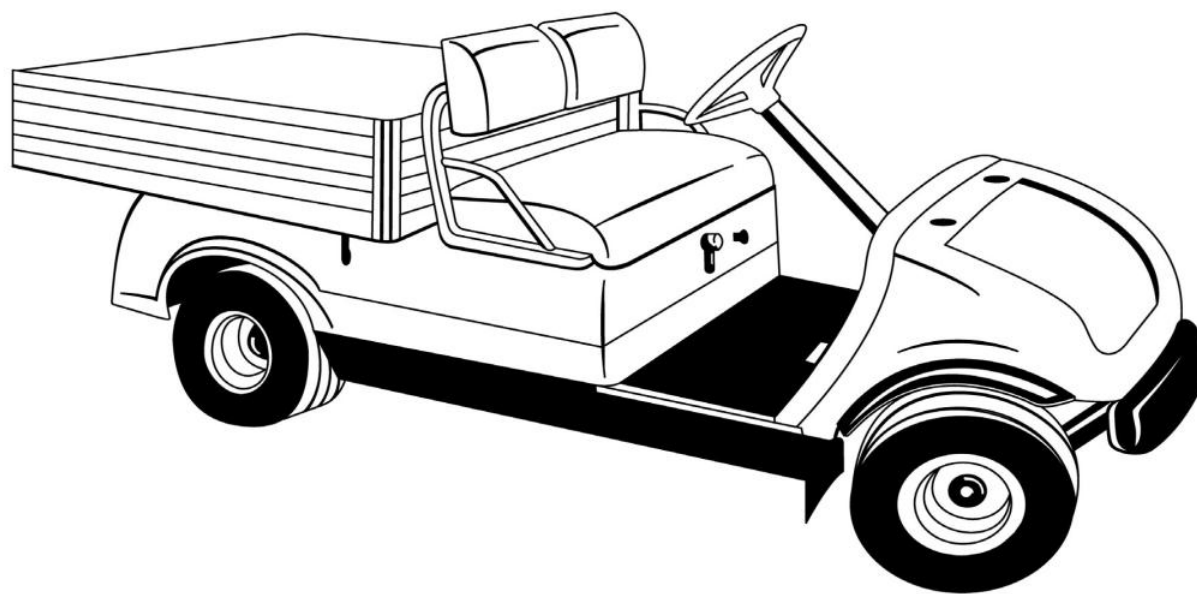

FOREWARD

This Parts Catalogue is related to the parts for the model(s) shown in the frame below. When you are ordering replacement parts, please refer to this Parts Catalogue and quote both part numbers and part names correctly.

G21A (JR61)

1. Modifications or additions which have been made after issue of the Parts Catalogue will be announced in the Yamaha Parts News. it is advisable that you make necessary corrections to the Parts Catalogue according to the Yamaha Parts News.

2. Abbreviations
The following abbreviations are used in this Parts Catalogue.

- "UR" Use specified part number.
- "UN" Use as many as needed.
- "AP" Alternate parts.
- "LM" Local Made (Parts need to be ordered locally)
- "F#" Frame Number (Applicable machine number)

3. Parts, which are to be supplied in an assembly, are listed with a dot (.) in front of the part name as shown below.

EXAMPLE
 CARBURETOR ASSY
 .JET, PILOT
 .NOZZLE, MAIN

4. Number of component for assembly
The numeral appearing to the right of each component part indicates the quantity of parts for each assembly unit.

EXAMPLE

PART NO.	DESCRIPTION	Q'TY	REMARKS
2F5-83310-60	FRONT FLASHER LIGHT ASSY	2	
115-83311-60	.BULB (6V-18W)	1	

5. Applicable colors of graphics are represented in the "REMARKS" as shown below.

PART NO.	DESCRIPTION	Q'TY	REMARKS
2N4-24110-00-X5	FUEL TANK COMP.	1	MAXIM RED
3J1-24240-10	.GRAPHIC, FUEL TANK	1	for MXR

6. Applicable Serial No. and Color Code

① Frame Serial No. JR6-300101 ~

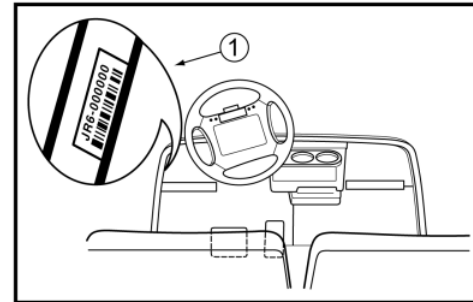

7. Note that the illustrations are for reference in finding parts numbers, not to be used for assembling. When assembling, please use the applicable service manual.

8. The asterisk (*) before a reference number indicates modification items after the first edition.

CONTENTS

ENGINE	PAGE		PAGE
Engine Assembly	5	Transmission	31 ~ 33
Cylinder Head	6	Rear Axle Mount / Wheel	34
Crankshaft / Piston	7	Shifter / Cables	35
Camshaft / Valve	8	Bumper	36
Air Shroud / Fan	9	Body (Front)	37 ~ 38
Intake	10	Body 2 (Rear)	39
Carburetor	11	Body Fitting	40
Exhaust	12	Carrier	41 ~ 42
Crankcase	13	Seat	43
		Starter Generator	44 ~ 45
		Electrical 1	46
		Electrical 2	47 ~ 48
CHASSIS			
Engine Mount	14		
Rear Arm / Suspension	15		
Frame	16		
Front Suspension / Wheel	17 ~ 18		
Steering	19 ~ 20		
Fuel Tank	21		
Brake	22 ~ 24		
Brake 2	25		
Brake 3	26		
Accelerator	27		
Governor	28		
Primary Clutch	29		
Secondary Sheave	30		

FIG. 1 ENGINE ASSEMBLY

REF NO.	PART NUMBER	DESCRIPTION	QTY	REMARKS
1	JR6-19001-00-00	ENGINE ASSEMBLY	1	

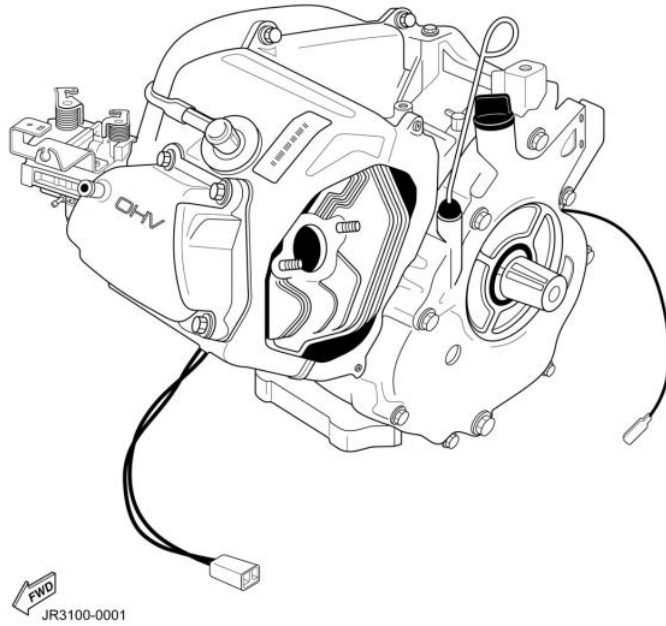
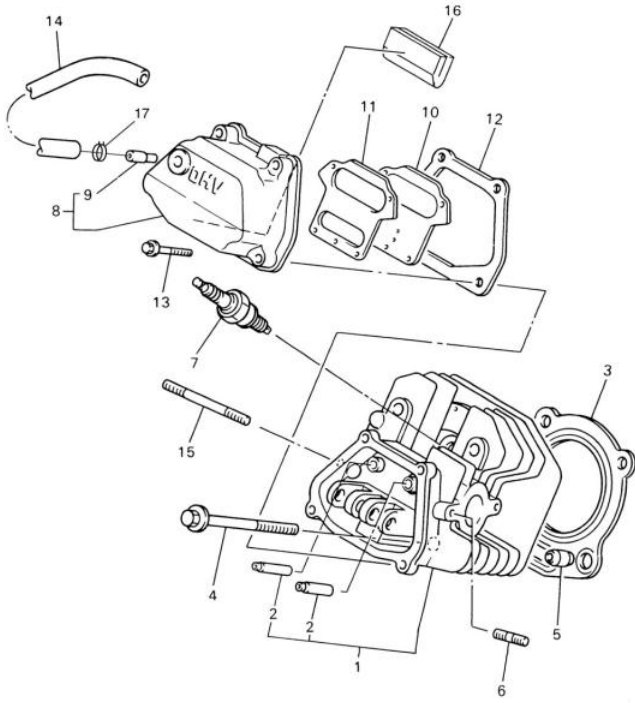

FIG. 2 CYLINDER HEAD



REF NO.	PART NUMBER	DESCRIPTION	QTY	REMARKS
1	JT0-11111-00-00	HEAD, CYLINDER 1	1	
2	JN6-11133-10-00	. GUIDE, INTAKE VALVE	2	
3	JT0-11181-00-00	GASKET, CYLINDER HEAD 1	1	
4	95817-10070-00	BOLT, FLANGE	4	
5	99530-14016-00	PIN, DOWEL A	2	
6	95617-08618-00	BOLT, STUD	2	
7	NGK-BPR2E-S0-00	PLUG, SPARK	1	STD, U.S.
	94702-00348-00	PLUG, SPARK	1	STD, EUROPE
	NGK-BPR4E-S0-00	PLUG, SPARK	1	AP, U.S.
	94702-00343-00	PLUG, SPARK	1	AP, EUROPE
8	JN6-11191-01-00	COVER, CYLINDER HEAD 1	1	
9	JN6-11116-00-00	. JOINT, BREATHER PIPE	1	
10	JN6-11168-00-00	COVER, BREATHER	1	
11	JN6-11169-00-00	GASKET, BREATHER COVER	1	
12	JN6-11193-00-00	GASKET, HEAD COVER 1	1	
13	95817-06030-00	BOLT, FLANGE	4	
14	JN6-E1166-00-00	PIPE, BREATHER 1	1	
15	95617-08710-00	BOLT, STUD	2	
16	JR7-11163-00-00	ELEMENT	1	
17	90467-13847-00	CLAMP	2	



JT01010-0011

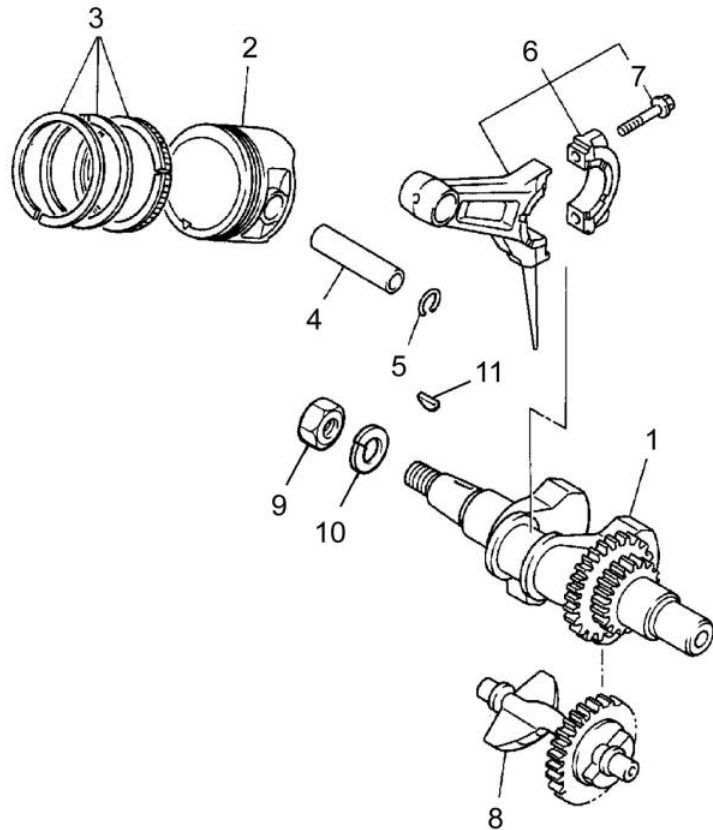

FIG. 3 CRANKSHAFT / PISTON

REF NO.	PART NUMBER	DESCRIPTION	QTY	REMARKS
1	JN6-11400-00-00	CRANK SHAFT ASSY.	1	
2	JR7-11631-00-A0	PISTON, (STD)	1	STD
	JR7-11635-00-00	PISTON, (0.25mm O/S)	1	AP
	JR7-11636-00-00	PISTON (0.50mm O/S)	1	AP
3	JR7-11610-00-00	PISTON RING SET, STD.	1	STD
	JR7-11610-10-00	PISTON RING SET, (0.25mm O/S)	1	AP
	JR7-11610-20-00	PISTON RING SET, (0.50mm O/S)	1	AP
4	583-11633-00-00	PIN, PISTON	1	
5	93450-21053-00	CIRCLIP	2	
6	JN6-11650-00-00	CONNECTING ROD ASSY	1	
7	JN6-11654-00-00	. BOLT, CONNECTING ROD	2	
8	JN6-11454-00-00	WEIGHT, 1	1	
9	95317-18600-00	NUT, HEX.	1	
10	90201-18620-00	WASHER, PLAIN	1	
11	90280-04052-00	KEY, WOODRUFF	1	



JN7010-6020

FIG. 4 CAMSHAFT / VALVE

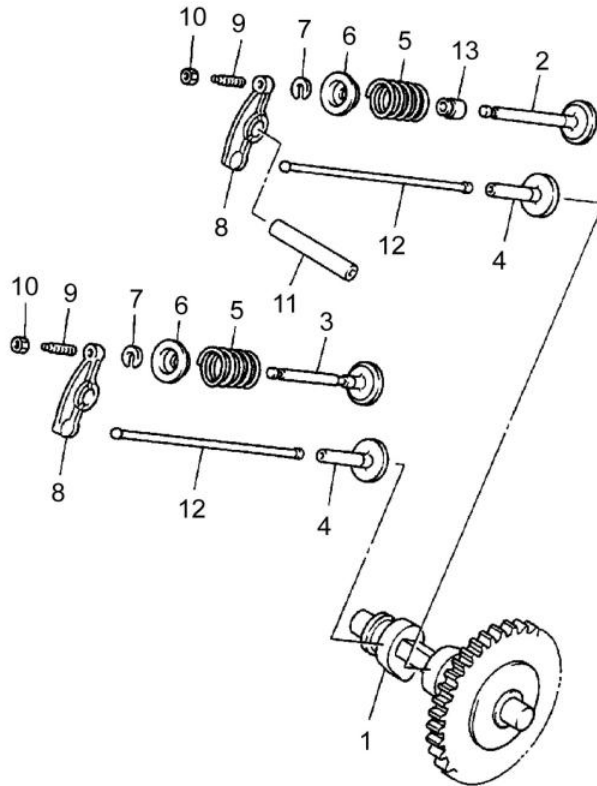

REF NO.	PART NUMBER	DESCRIPTION	QTY	REMARKS
1	JR7-12170-00-00	CAMSHAFT ASSY. 1	1	
2	JN6-12111-01-00	VALVE, INTAKE	1	
3	7RH-12121-00-00	VALVE, EXHAUST	1	
4	JN6-12153-00-00	LIFTER, VALVE	2	
5	90501-264A9-00	SPRING, COMPRESSION	2	
6	J38-12117-01-00	RETAINER, VALVE SPRING	2	
7	J38-12118-00-00	COTTER, VALVE	2	
8	JN6-12151-00-00	ARM, VALVE ROCKER	2	
9	22F-12159-00-00	SCREW, VALVE ADJUSTING	2	
10	90170-05302-00	NUT, HEX.	2	
11	J38-12156-00-00	SHAFT, ROCKER 2	1	
12	JR7-12154-01-00	ROD, VALVE PUSH	2	
13	5H0-12119-00-00	SEAL, VALVE STEM	1	



JN7010-6030

FIG. 5 AIR SHROUD / FAN

REF NO.	PART NUMBER	DESCRIPTION	QTY	REMARKS
1	JN6-12621-00-00	CASE, FAN	1	
2	95817-06020-00	BOLT, FLANGE	5	
3	JN6-12616-00-00	COVER, FAN CASE	1	
4	97707-60520-00	SCREW, PAN HEAD	3	
5	JN6-12651-00-00	AIR SHROUD, CYLINDER 1	1	
6	JR7-12658-00-00	DAMPER AIR SHROUD 1	1	
7	JN6-12652-00-00	AIR SHROUD, CYLINDER 2	1	
8	95817-06020-00	BOLT, FLANGE	2	
9	JN6-E2691-00-00	DUCT, 1	1	
10	90269-08813-00	RIVET	2	

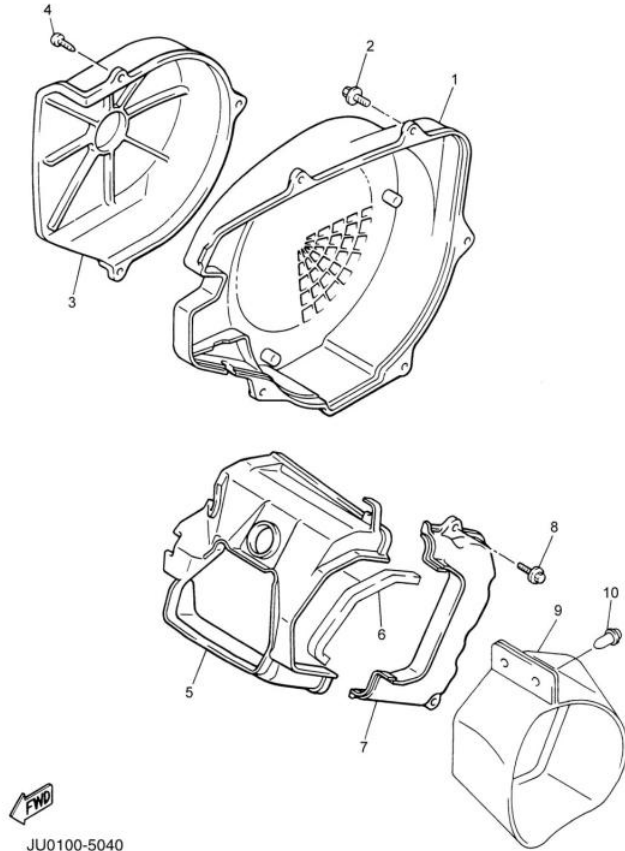
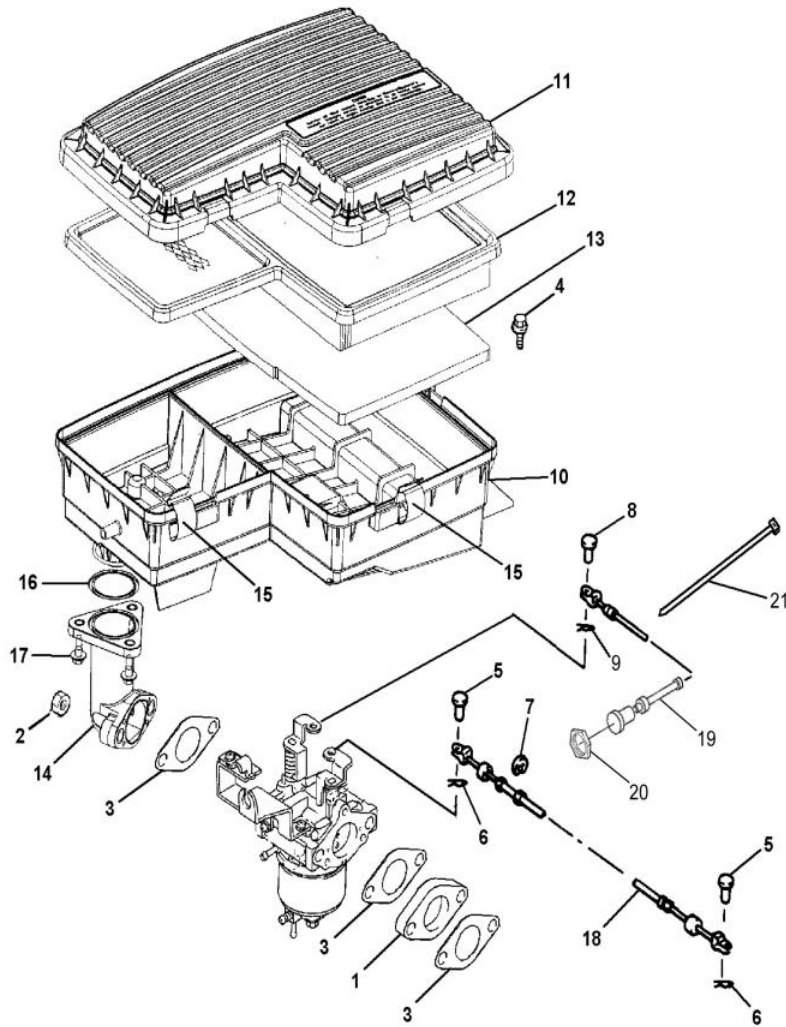

FIG. 6 INTAKE



 JR6100-5050

REF NO.	PART NUMBER	DESCRIPTION	QTY	REMARKS
1	JN6-13595-00-00	JOINT	1	
2	90179-08491-00	NUT, FLANGE	2	
3	JN6-13567-00-00	GASKET	3	
4	90119-06838-00	BOLT, HEX HEAD W/WASHER	2	
5	91790-05010-00	PIN, CYL. HEAD W/HOLE	2	
6	90468-10050-00	CLIP	2	
7	99080-07600-00	CIRCLIP (E)	1	
8	91790-05010-00	PIN, CYL. HEAD W/HOLE	1	
9	90468-10050-00	CLIP	1	
10	JN6-E4411-02-00	CASE, AIR FILTER	1	
11	JN6-E4412-01-00	CAP, CASE 1	1	
12	JN6-E4450-01-00	ELEMENT ASSY.	1	
13	JN6-E445E-00-00	FILTER, 1	1	
14	JN6-E3586-01-00	JT., CARBURETOR 1	1	
15	JN6-E4424-00-00	CLIP, CAP FITTING	5	
16	93210-398D6-00	O-RING	1	
17	90105-06862-00	BOLT, FLANGE	3	
18	JN6-F6312-01-00	WIRE, THROTTLE 2	1	
19	J55-F6331-11-00	WIRE, STARTER	1	
20	JN6-F6333-10-00	NUT	1	
21	90464-31827-00	CLAMP	1	

FIG. 7 CARBURETOR

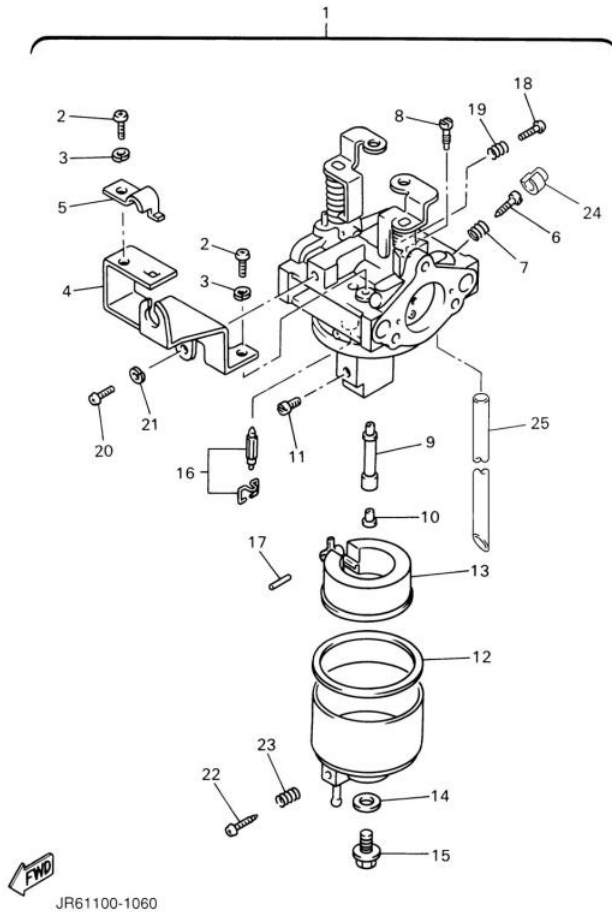

REF NO.	PART NUMBER	DESCRIPTION	QTY	REMARKS
1	JR6-14101-00-00	CARBURETOR ASSY.	1	
2	98507-05100-00	. SCREW, PAN HEAD	2	
3	92990-05100-00	. WASHER	2	
4	JN6-14291-00-00	. BRACKET 1	1	
5	J10-14227-00-00	. WASHER	1	
6	7NJ-14211-00-00	. SCREW, PILOT ADJUSTING	1	
7	73A-14212-10-00	. SPRING, PILOT ADJUSTING	1	
8	732-14142-65-A0	. JET, PILOT	1	(#65.0)
9	JN6-1495H-3B-00	. NOZZLE, MAIN	1	
10	73A-1414G-00-00	. PIPE, MAIN BLEED	1	
11	3G2-1423A-68-A0	. JET, MAIN	1	(# 87.5)
12	796-14184-00-00	. GASKET, FLOAT CHAMBER	1	
13	JN6-14185-00-00	. FLOAT	1	
14	127-14198-00-00	. GASKET	1	
15	7R1-14162-00-00	. BOLT, HOLDING	1	
16	JN5-14150-00-00	. NEEDLE ASSY	1	
17	22F-14186-00-00	. PIN, FLOAT	1	
18	1WG-14922-00-00	. SCREW, THROTTLE	1	
19	73A-14212-10-00	. SPRING, PILOT ADJUSTING	1	
20	98507-04010-00	. SCREW, PAN HEAD	1	
21	92903-04100-00	. WASHER	1	
22	7E1-14191-00-00	. PLUG, DRAIN	1	
23	73A-14212-00-00	. SPRING, PILOT ADJUSTING	1	
24	7LV-14118-00-00	. CAP	1	
25	1KT-14197-01-00	. PIPE	1	

FIG. 8 EXHAUST

REF NO.	PART NUMBER	DESCRIPTION	QTY	REMARKS
1	JN6-E4710-00-00	MUFFLER ASSEMBLY	1	
2	7KY-14613-01-00	GASKET, EXHAUST 1	1	
3	90179-08879-00	NUT	2	
4	90185-08841-00	NUT, U-FLANGE	1	
5	90119-08825-00	BOLT, HEX HEAD W/WASHER	2	
6	JN6-F1435-10-00	BRACKET, MUFFLER	1	

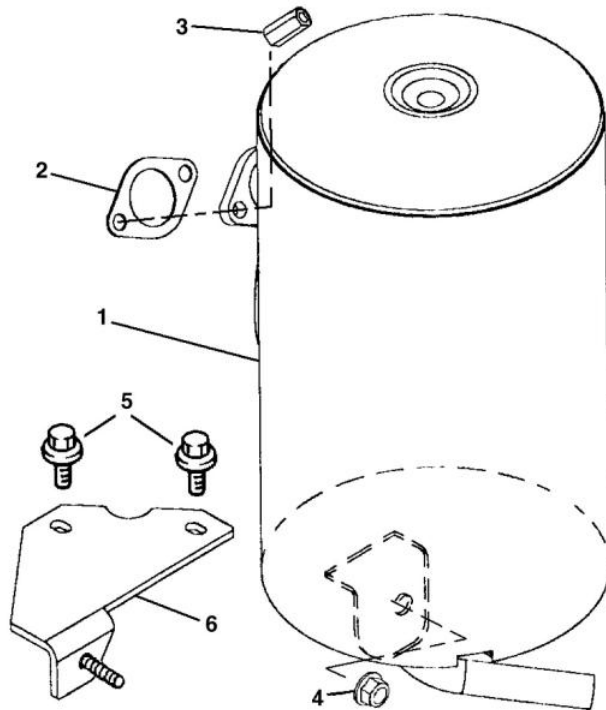

 JN6100-6021

FIG. 9 CRANKCASE

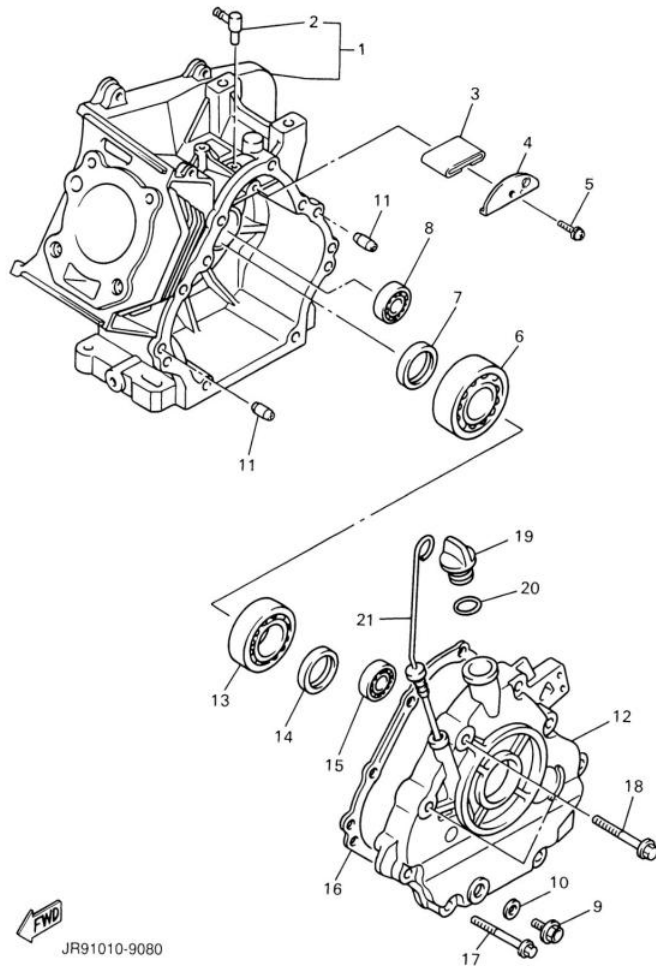

REF NO.	PART NUMBER	DESCRIPTION	QTY	REMARKS
1	JR7-15100-00-00	CRANKCASE ASSY	1	
2	JN6-15155-00-00	. NOZZLE, 3	1	
3	JR7-15407-00-00	ELEMENT 1	1	
4	JR7-15123-00-00	PLATE, BAFFLE	1	
5	90159-06107-00	SCREW, W/WASHER	1	
6	93306-30709-00	BEARING	1	
7	93102-35014-00	SEAL, OIL	1	
8	93306-20211-00	BEARING	1	
9	90340-12097-00	PLUG, STRAIGHT SCREW	1	
10	812-11198-00-00	GASKET	1	
11	91808-16023-00	PIN, DOWEL A	2	
12	JN6-15411-00-00	COVER, CRANKCASE	1	
13	93306-20716-00	BEARING	1	
14	93102-35014-00	SEAL, OIL	1	
15	93306-20211-00	BEARING	1	
16	JN6-15451-02-00	GSKT., CRANKCASE COVER 1	1	
17	95817-08045-00	BOLT, FLANGE	6	
18	95817-10050-00	BOLT, FLANGE	2	
19	7EN-51118-00-00	PLUG, OIL	1	
20	93210-22344-00	O-RING	1	
21	J38-15361-00-00	GAUGE, LEVEL	1	

FIG. 10 ENGINE MOUNT

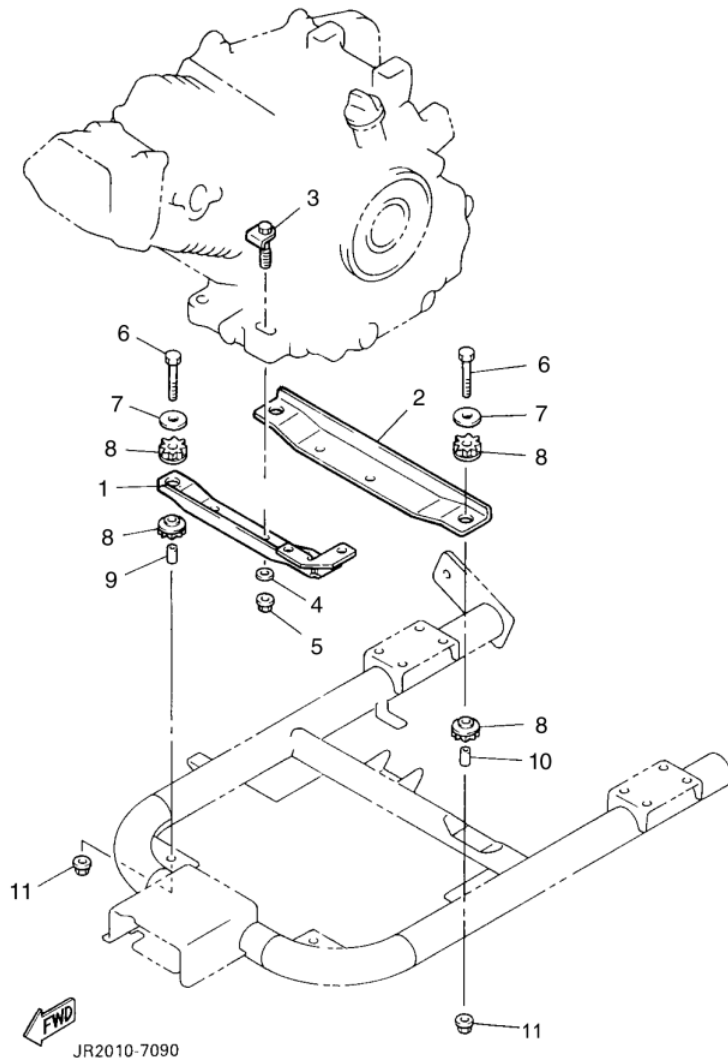

REF NO.	PART NUMBER	DESCRIPTION	QTY	REMARKS
1	JN6-F1411-00-00	BRACKET, ENGINE 1	1	
2	JN6-F1419-02-00	BRACKET, ENGINE 2	1	
3	JN6-F1481-00-00	BOLT, ENGINE	4	
4	92907-10200-00	WASHER, PLAIN	4	
5	9560P-10200-00	NUT, U-FLANGE	4	
6	90101-08870-00	BOLT, HEX	4	
7	90201-088K6-00	WASHER, PLAIN	4	
8	JN6-F1486-00-00	DAMPER, 2	8	
9	JN6-F1459-00-00	SPACER	2	
10	JN6-F1459-10-00	SPACER	2	
11	90185-08169-00	NUT, U-FLANGE	4	

FIG. 11 REAR ARM / SUSPENSION

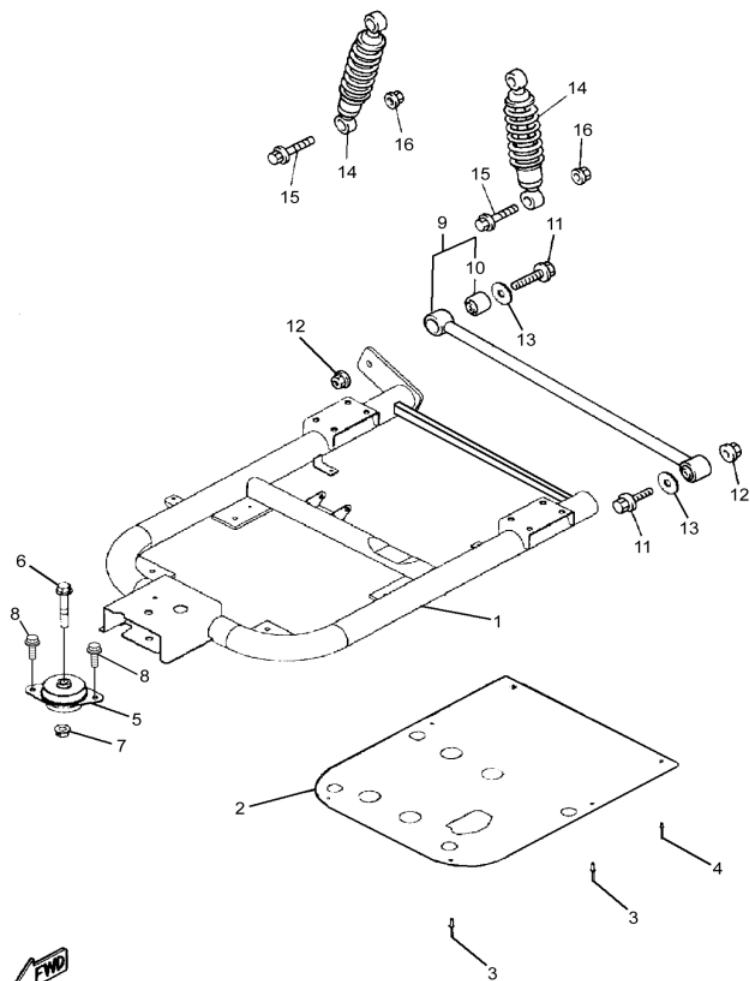

REF NO.	PART NUMBER	DESCRIPTION	QTY	REMARKS
1	JN6-F2110-02-00	REAR ARM COMP.	1	
2	JN6-F2128-01-00	COVER, 1	1	
3	90267-48850-00	RIVET, BLIND	4	
4	90267-40851-00	RIVET, BLIND	2	
5	JN6-F2123-01-00	BUSHING, 1	1	
6	90105-13864-00	BOLT, FLANGE	1	
7	90179-13878-00	NUT	1	
8	9751P-10620-00	BOLT,HEX. WWASHER (7-FQA)	2	
9	JN6-F2172-00-00	ROD, CONNECTING ASSY.	1	
10	JN6-F2124-00-00	. BUSHING, 2	2	
11	95817-12065-00	BOLT, FLANGE	2	
12	95607-12200-00	NUT, U-FLANGE	2	
13	90201-12426-00	WASHER, PLAIN	2	
14	JR6-F2210-00-00	SHOCK ABSORBER	2	
15	95817-10055-00	BOLT, FLANGE	4	
16	95607-10200-00	NUT, U-FLANGE	4	

JR6100-7020

FIG. 12 FRAME

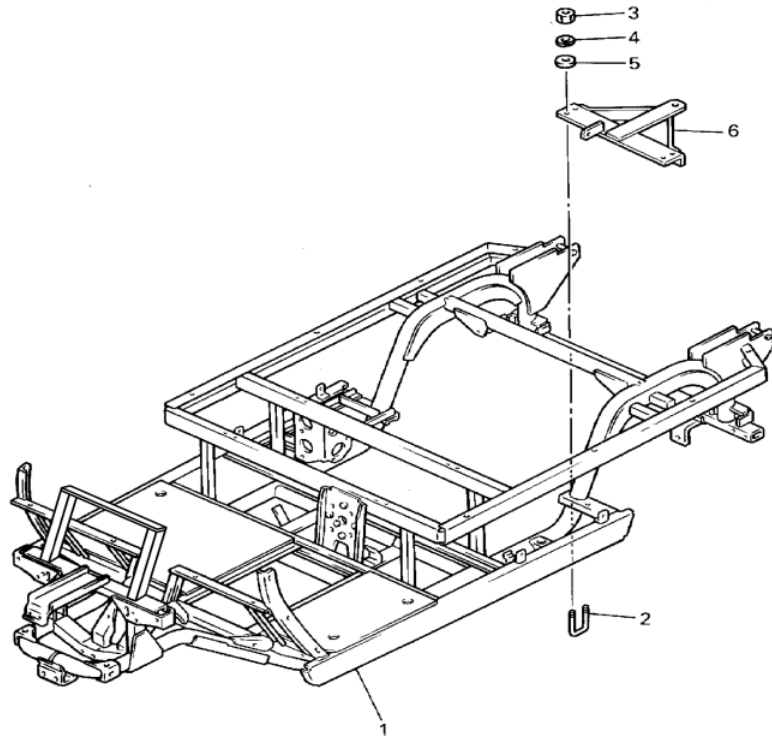

REF NO.	PART NUMBER	DESCRIPTION	QTY	REMARKS
1	JR6-F2501-01-00	FRAME COMP.	1	
2	90109-10862-00	BOLT	2	
3	90170-10847-00	NUT, HEX	4	
4	92907-10100-00	WASHER, SPRING	4	
5	92907-10200-00	WASHER, PLAIN	4	
6	JJ3-F722B-02-00	BAR, TOW	1	

 JR6110-6110

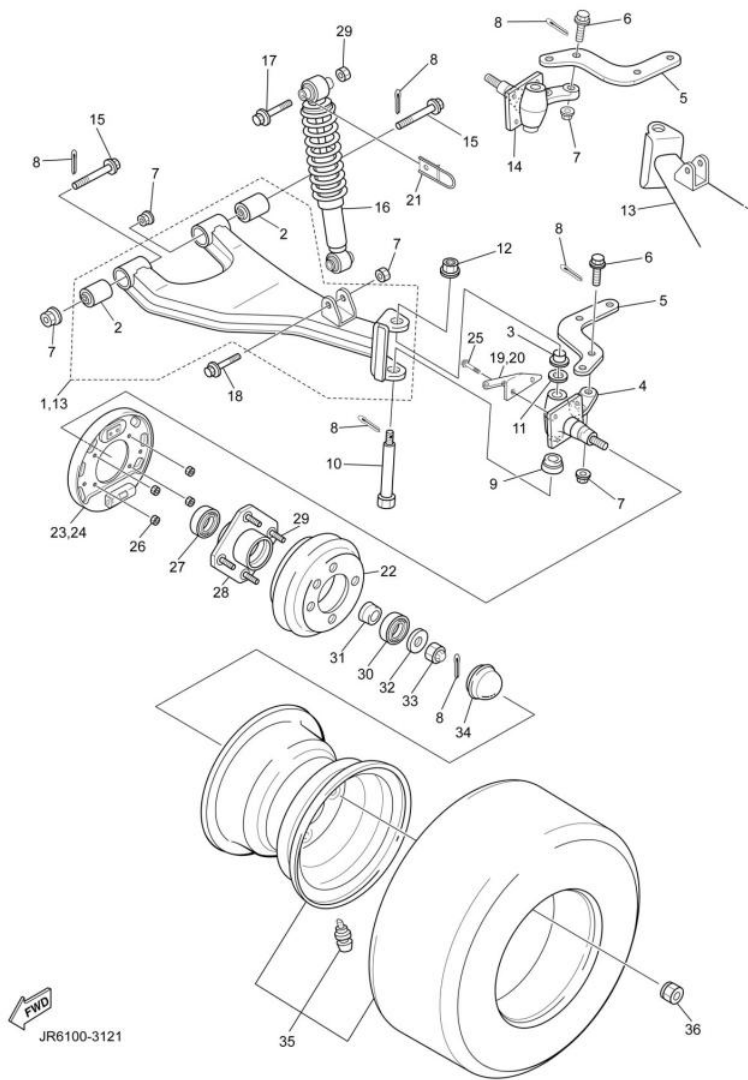
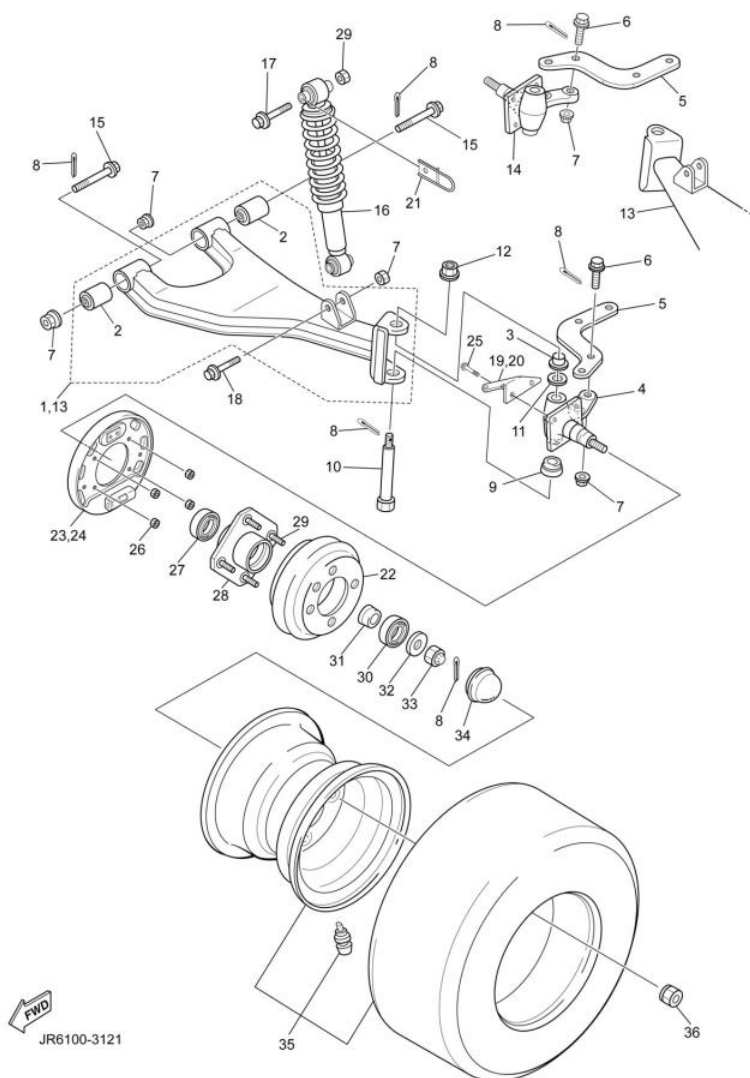

FIG. 13 FRONT SUSPENSION / WHEEL

REF NO.	PART NUMBER	DESCRIPTION	QTY	REMARKS
1	JR6-F3570-00-00	FRONT LOWER ARM, LEFT	1	
2	JN6-F3526-00-00	. BUSHING, ARM	4	
3	90384-15825-00	BUSH, BIMETAL	2	
4	JR6-F3501-00-00	STRG. KNUCKLE ASSY.,LH.	1	
5	JN3-F3512-00-00	ARM,KNUCKLE LH.	2	
6	90105-10895-00	BOLT, FLANGE	4	
7	95607-10200-00	NUT, U-FLANGE	12	
8	91490-25020-00	PIN, SPLIT	12	
9	J38-23527-00-00	SEAL, DUST 1	2	
10	JR6-F3516-00-00	PIN,STRG. KNUCKLE KING	2	SEE NOTE "A"
11	90201-158S6-00	WASHER, PLAIN	2	
12	9560P-10200-00	NUT, U-FLANGE	2	SEE NOTE "A"
13	JR6-F3580-00-00	FRONT LOWER ARM, RIGHT	1	
14	JR6-F3502-00-00	KNUCKLE, STEERING RIGHT	1	
15	90105-10894-00	BOLT, FLANGE	4	
16	JR6-F3350-00-00	SHOCK ABSORBER ASSY	2	
17	95817-10065-00	BOLT	2	
18	95817-10055-00	BOLT	2	
19	JR6-F7263-00-00	BRKT. 1 (LH)	1	
20	JR6-F7264-00-00	BRKT. 2 (RH)	1	
21	JR6-F1339-00-00	GUIDE WIRE	2	
22	J55-G6521-10-00	DRUM	2	
23	JN6-F7290-03-00	BACKING PLATE ASSY (LH)	1	SEE PAGE 26 FOR COMPONENT PARTS
24	JN6-F7280-03-00	BACKING PLATE ASSY (RH)	1	SEE PAGE 25 FOR COMPONENT PARTS
25	9502P-08025-00	BOLT	8	
26	9560P-08200-00	NUT	8	
27	93306-005Y3-00	BEARING	2	

NOTE "A": The King Pin (Ref #10) was changed from 12mm (old PN JJ3-F3516-00) to 10mm threads (new PN JR6-F3516-00), and the flange nut (Ref #12) was changed from 12mm (95607-12200-00) to 10mm (9560P-10200). To determine which parts you are working with, measure the thread diameter of your existing components. The old King Pin (JJ3-F3516-00) is not available and has been superceded to JR6-F3516-00. Be sure to also order the new 10mm flange nut (Ref # 12) to update ol

FIG. 13 FRONT SUSPENSION / WHEEL



REF NO.	PART NUMBER	DESCRIPTION	QTY	REMARKS
28	JR6-F5110-00-00	HUB	2	
29	90114-12803-00	BOLT KNURLED	8	
30	93306-204X0-00	BEARING	2	
31	90387-241M7-00	COLLAR	2	
32	90209-32832-00	WASHER	2	
33	95617-14100-00	NUT, U	2	
34	JN6-F5118-00-00	COVER, HUB DUST	2	
35	JN6-F5100-11-00	FR. WHEEL ASSY	2	
36	90179-12262-00	NUT	8	

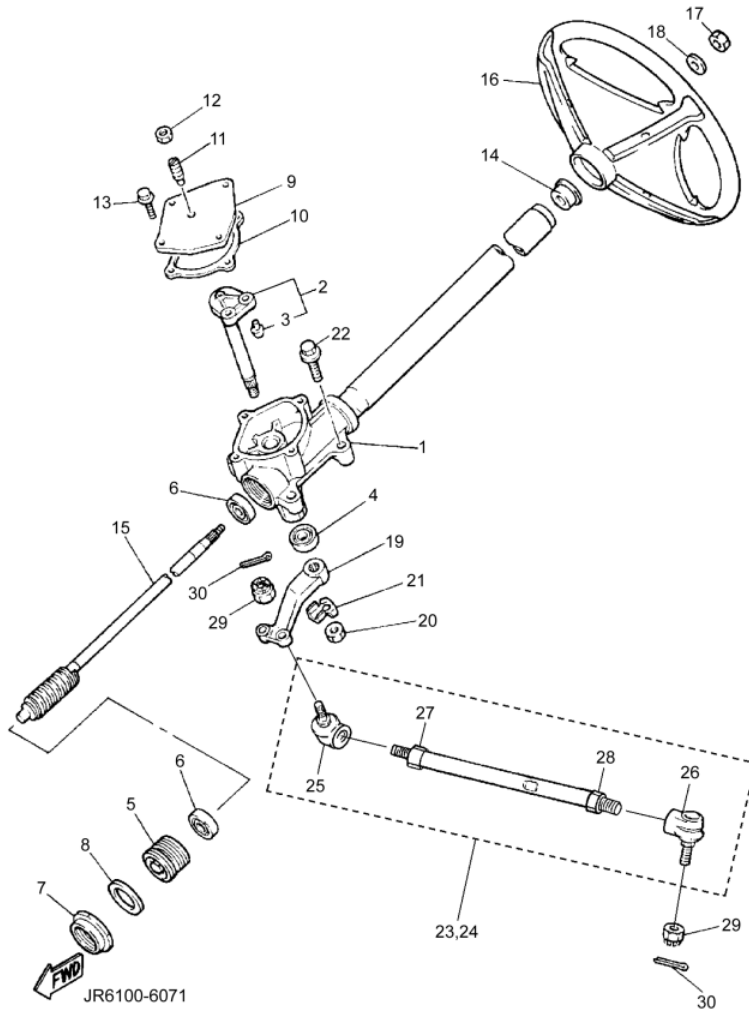

FIG. 14 STEERING

REF NO.	PART NUMBER	DESCRIPTION	QTY	REMARKS
1	JG5-F3811-00-00	COLUMN, STEERING	1	
2	J38-23816-00-00	ARM, PITMAN	1	
3	J38-23836-00-00	. PIN, PITMAN	2	
4	93102-22314-00	SEAL, OIL	1	
5	J55-F3876-00-00	BOLT	1	
6	93332-000Y2-00	BEARING	2	
7	J10-23877-00-00	NUT	1	
8	J10-23444-00-00	WASHER	1	
9	JN3-F3818-00-00	COVER, STEERING	1	
10	J38-23462-01-00	SEAL, STEERING	1	
11	J10-F3459-00-00	BOLT	1	
12	90170-08024-00	NUT, HEX.	1	
13	95817-06020-00	BOLT, FLANGE	4	
14	JN3-F3814-00-00	HOLDER, HANDLE	1	
15	J10-23840-00-00	STEERING SHAFT	1	
16	JN3-F3838-00-00	WHEEL, STEERING	1	
17	95617-12100-00	NUT, SELF-LOCKING	1	
18	92907-12200-00	WASHER, PLAIN	1	
19	J38-23826-01-00	ARM, IDLER	1	
20	95707-16300-00	NUT, NYLON	1	
21	90215-16814-00	WASHER, TONGUE	1	
22	90105-10880-00	BOLT, FLANGE	4	
23	JN6-F3850-11-00	TIE ROD ASSY, RIGHT	1	
24	JN6-F3830-11-00	TIE ROD ASSY, LEFT	1	
25	JN6-F3845-00-00	. UNIVERSAL JOINT	2	
26	JN6-F3841-00-00	. UNIVERSAL JOINT	2	
27	9530N-10600-00	. NUT, (RH THREAD)	2	

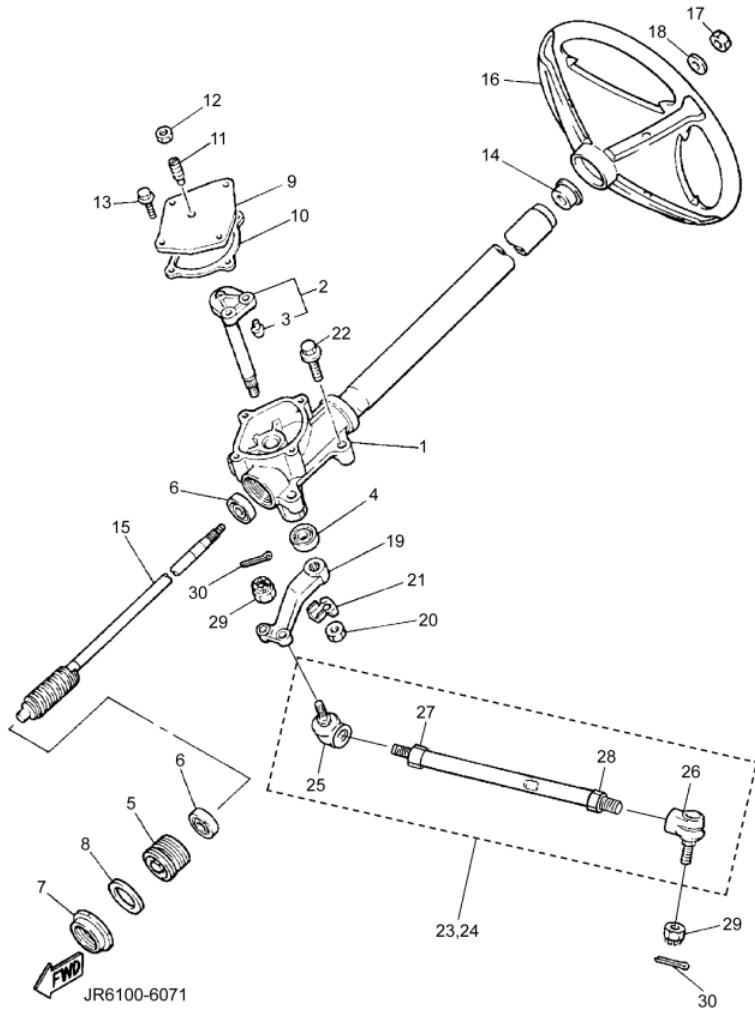

FIG. 14 STEERING

REF NO.	PART NUMBER	DESCRIPTION	QTY	REMARKS
28	90170-10414-00	. NUT (LH THREAD)	2	
29	95607-10200-00	NUT, U-FLANGE	4	
30	91401-25020-00	PIN, SPLIT	4	

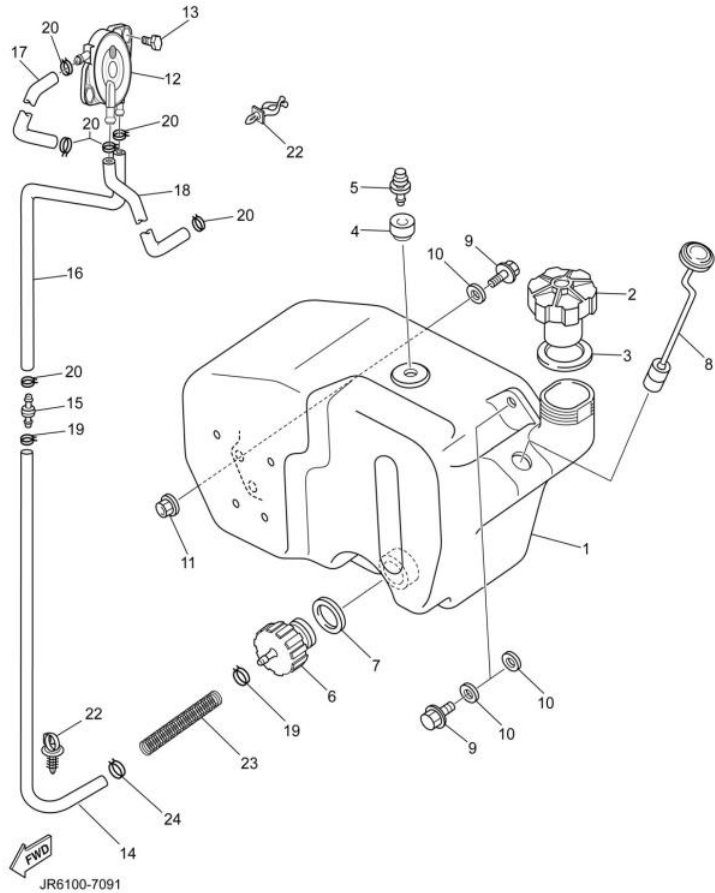
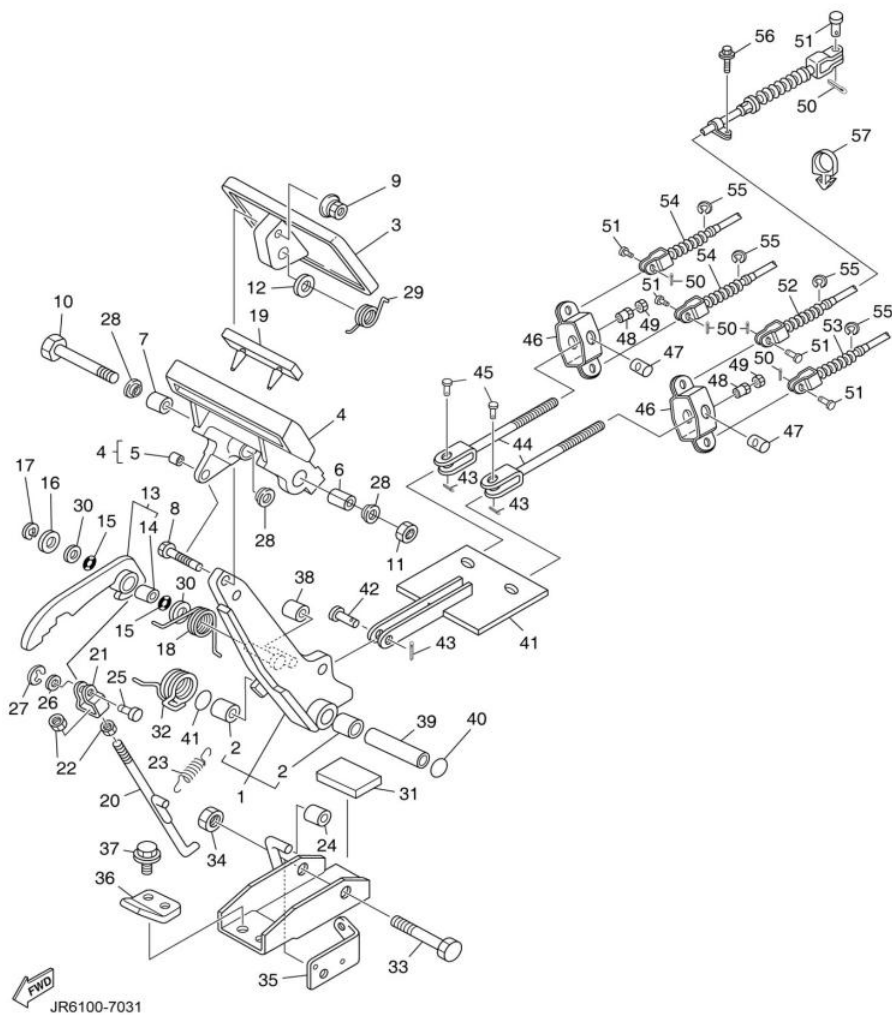

FIG. 15 FUEL TANK

REF NO.	PART NUMBER	DESCRIPTION	QTY	REMARKS
1	J55-F4111-12-00	TANK, FUEL	1	
2	J24-24620-01-00	BODY CAP ASSY	1	
3	J10-24612-00-00	GASKET, CAP	1	
4	J10-21773-00-00	GROMMET	1	
5	J24-24460-01-00	RELEASE VALVE ASSY.	1	
6	8R4-24560-00-00	FILTER ASSY.	1	
7	8F3-24564-00-00	GASKET	1	
8	J38-85710-02-00	FUEL LEVEL GAUGE ASSY.	1	
9	97017-08025-00	BOLT HEX. HEAD W/WASHER	3	
10	90201-088S2-00	WASHER, PLATE	4	
11	9560P-08200-00	NUT, U FLANGE	2	
12	JN6-F4410-10-00	FUEL PUMP ASSY.	1	
13	JN6-F3394-00-00	BOLT, SPECIAL	2	
14	JR3-F4312-00-00	PIPE 2	1	
15	JR3-F4461-00-00	PIPE, JOINT	1	
16	JN6-F4311-00-00	PIPE, FUEL	1	
17	JN6-F4313-10-00	PIPE 3	1	
18	JR3-F4314-10-00	PIPE 4	1	
19	90467-12845-00	CLIP	2	
20	90467-10846-00	CLIP	6	
21	90464-11816-00	CLAMP	1	
22	90464-12830-00	CLAMP	1	
23	90501-08707-00	SPRING COMPRESSION	1	
24	90467-10846-00	CLIP	1	

FIG. 16 BRAKE



REF NO.	PART NUMBER	DESCRIPTION	QTY	REMARKS
1	J46-27250-03-00	BRAKE ARM COMP	1	
2	90384-14080-00	. BUSH, BIMETAL FORMED	2	
3	J10-27211-00-00	PEDAL, BRAKE	1	
4	J17-25671-01-00	PARKING PEDAL COMP.	1	
5	90384-05163-00	.BUSH, BIMETAL	1	
6	90387-08014-00	COLLAR	1	
7	90387-08013-00	COLLAR	1	
8	97017-06035-00	BOLT, HEX.	1	
9	90179-06387-00	NUT	1	
10	97027-08100-00	BOLT, HEX.	1	
11	95337-08600-00	NUT, HEX.	1	
12	92907-08200-00	WASHER, PLAIN	1	
13	J17-25666-02-00	SECTOR, PARKING BRAKE	1	
14	90384-10162-00	. BUSH, BIMETAL	1	
15	J17-27221-00-00	SEAL, SHAFT	2	
16	92907-10600-00	WASHER, PLAIN	1	
17	99080-07600-00	CIRCLIP (E)	1	
18	90508-14548-00	SPRING, TORSION	1	
19	J17-25672-01-00	PAD, PARKING	1	
20	J17-27231-03-00	ROD, BRAKE	1	
21	J17-27232-00-00	END, ROD 1	1	
22	95317-06700-00	NUT, HEX.	2	
23	90506-08526-00	SPRING, TENSION	1	
24	J17-25673-00-00	DAMPER, BRAKE	1	
25	J17-27228-00-00	PIN, LINK JOINT	1	
26	92907-05600-00	WASHER, PLAIN	1	
27	99080-04600-00	CIRCLIP (E)	1	

FIG. 16 BRAKE

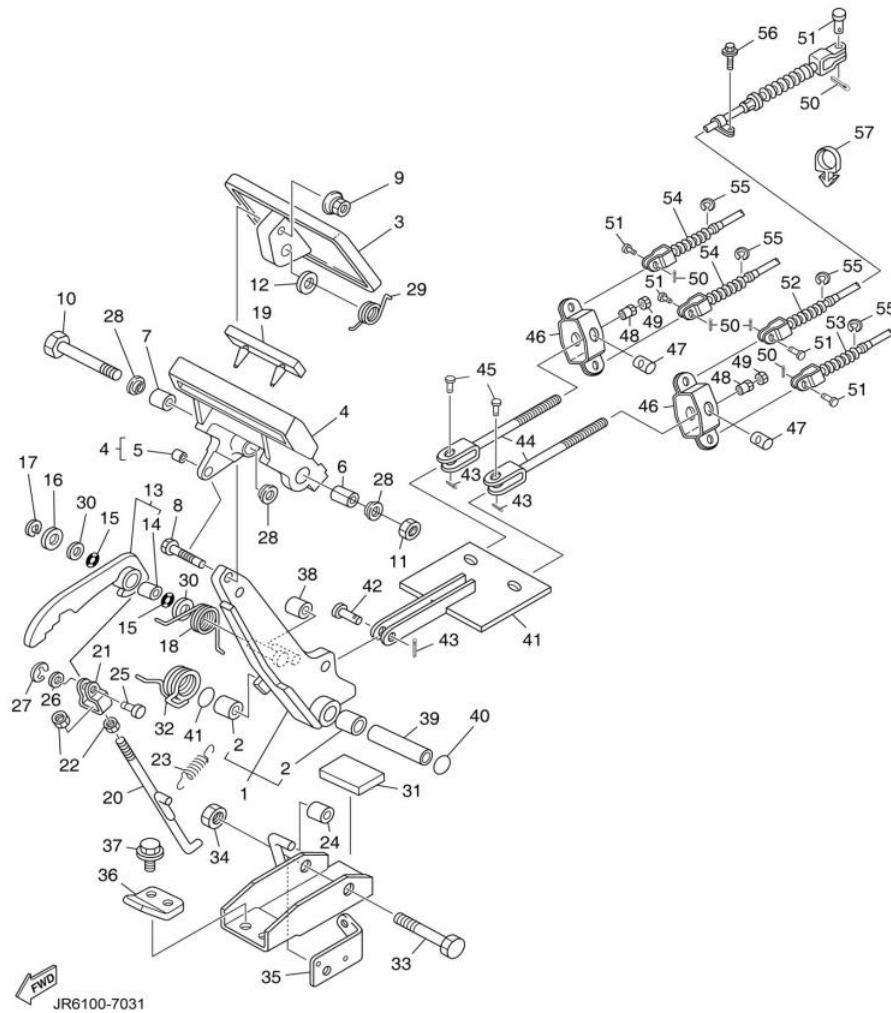

REF NO.	PART NUMBER	DESCRIPTION	QTY	REMARKS
28	90387-12009-00	BUSH	3	
29	90508-32015-00	SPRING, TORSION	1	
30	92907-08200-00	PLATE	2	
31	JN3-F7245-00-00	PAD, BRAKE PEDAL	1	
32	90508-40007-00	SPRING, TORSION	1	
33	90101-10884-00	BOLT, HEX.	1	
34	95607-10200-00	NUT, U-FLANGE	1	
35	J55-2252M-00-00	BRACKET, 3	1	
36	J17-27246-00-00	NAIL, BRAKE	1	
37	90105-08878-00	BOLT, FLANGE	2	
38	J17-25673-00-00	DAMPER, BRAKE	1	
39	90387-107F8-00	COLLAR	1	
40	93210-14579-00	O-RING	2	
41	JR6-F7215-00-00	LINK	1	
42	91701-10026-00	PIN	1	
43	91490-30020-00	PIN, SPLIT	3	
44	JN6-F5685-00-00	ROD	2	
45	91701-10022-00	PIN	2	
46	J10-25681-00-00	EQUALIZER, BRAKE	2	
47	90249-14129-00	PIN	2	
48	90179-08894-00	NUT	2	
49	95307-08700-00	NUT, HEX	2	
50	91490-25020-00	PIN, SPLIT	8	
51	91701-08018-00	PIN	8	
52	JJ3-F6341-01-00	WIRE, BRAKE 1	1	
53	JJ3-F6351-02-00	WIRE, BRAKE 2	1	
54	JR6-F6361-00-00	WIRE, BRAKE 3	2	

FIG. 16 BRAKE

REF NO.	PART NUMBER	DESCRIPTION	QTY	REMARKS
55	99001-09600-00	CIRCLIP E	8	
56	95817-06016-00	BOLT, FLANGE	2	
57	90464-19815-00	CLAMP	1	

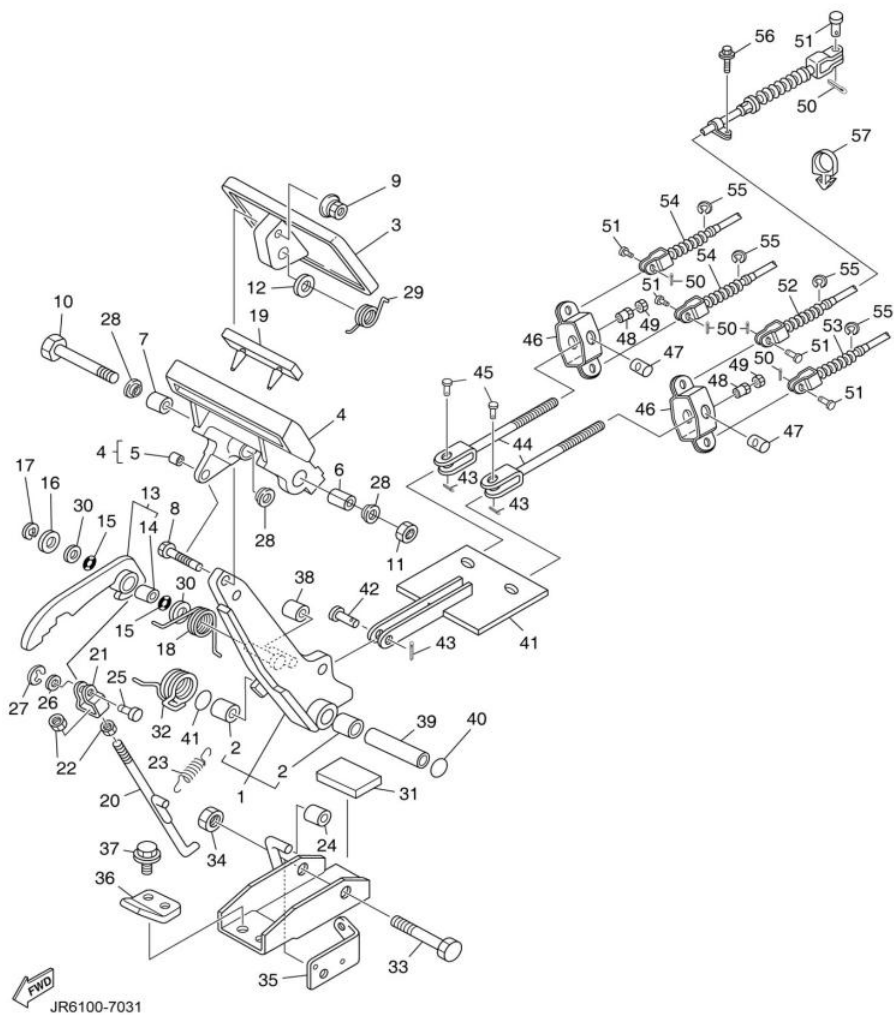
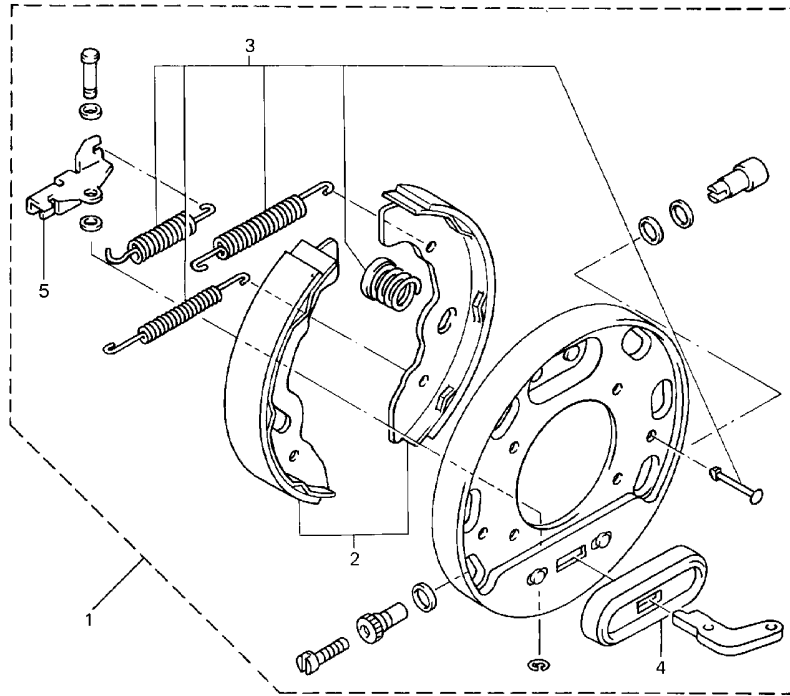

FIG. 17 BRAKE 2



REF NO.	PART NUMBER	DESCRIPTION	QTY	REMARKS
1	JN6-F7280-03-00	BACKING PLATE, (RH)	2	(FOR R/S FRONT & REAR WHEELS ONLY)
2	JN6-F5331-01-00	. SHOE, BRAKE SET	1	(FOR ONE WHEEL)
3	JN6-F819G-00-00	. REPAIR PARTS KIT	2	
4	JG5-F7286-00-00	. COVER, DUST	2	
5	JN6-F722F-00-00	. LEVER ADJUSTER, (RH)	2	



JN4100-5061

FIG. 18 BRAKE 3

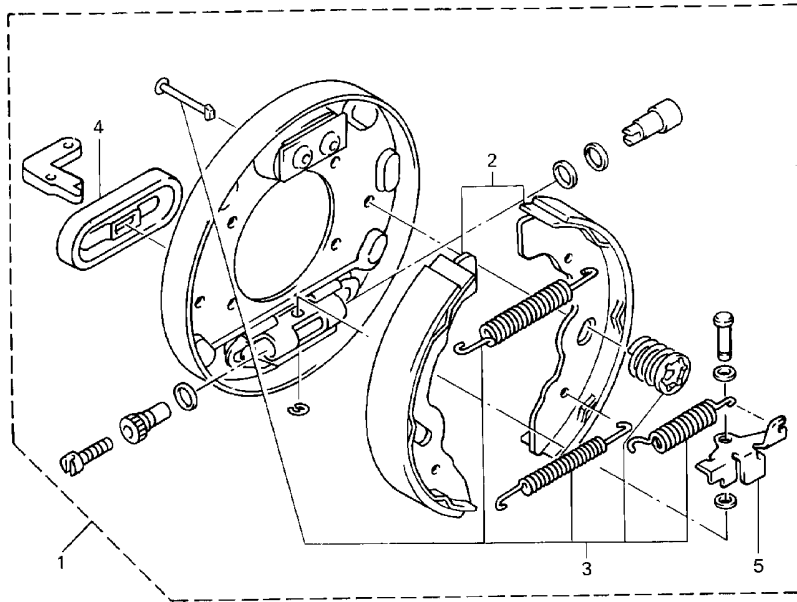

REF NO.	PART NUMBER	DESCRIPTION	QTY	REMARKS
1	JN6-F7290-03-00	BACKING PLATE, (LH)	2	(FOR L/S FRONT & REAR WHEELS ONLY)
2	JN6-F5331-01-00	. SHOE, BRAKE SET	1	(FOR ONE WHEEL)
3	JN6-F819G-00-00	. REPAIR PARTS KIT	2	
4	JG5-F7286-00-00	. COVER, DUST	2	
5	JN6-F722E-00-00	. LEVER ADJUSTER, (LH)	2	

 JN4100-5071

FIG. 19 ACCELERATOR



REF NO.	PART NUMBER	DESCRIPTION	QTY	REMARKS
1	JN6-F7874-01-00	BRACKET, PEDAL	1	
2	J17-27853-01-00	SHAFT, PEDAL	1	
3	J38-27872-00-00	ARM, ACCELERATOR	1	
4	91609-60028-00	PIN, SPRING	1	
5	91609-35028-00	PIN, SPRING	1	
6	J10-27871-01-00	PEDAL, ACCELERATOR	1	
7	95817-06025-00	BOLT, FLANGE	1	
8	90106-08806-00	BOLT, RD. HEX	1	
9	90179-08491-00	NUT, FLANGE	1	
10	90384-14080-00	BUSH, BIMETAL FORMED	2	
11	93210-14579-00	O-RING	4	
12	JN3-F7854-00-00	COVER, PEDAL	1	
13	90105-08878-00	BOLT, FLANGE	3	
14	90506-26282-00	SPRING, TENSION	1	
15	JJ3-F6311-00-00	WIRE, THROTTLE	1	
16	91790-05012-00	PIN	1	
17	90468-10050-00	CLIP	1	
18	90508-16460-00	SPRING, TORSION	1	
19	90560-05001-00	SPACER	1	
20	95817-06025-00	BOLT, FLANGE	1	
21	95707-06500-00	NUT, FLANGE	1	
22	90464-40825-00	CLAMP	1	
23	90387-068T4-00	COLLAR	1	

FIG. 20 GOVERNOR

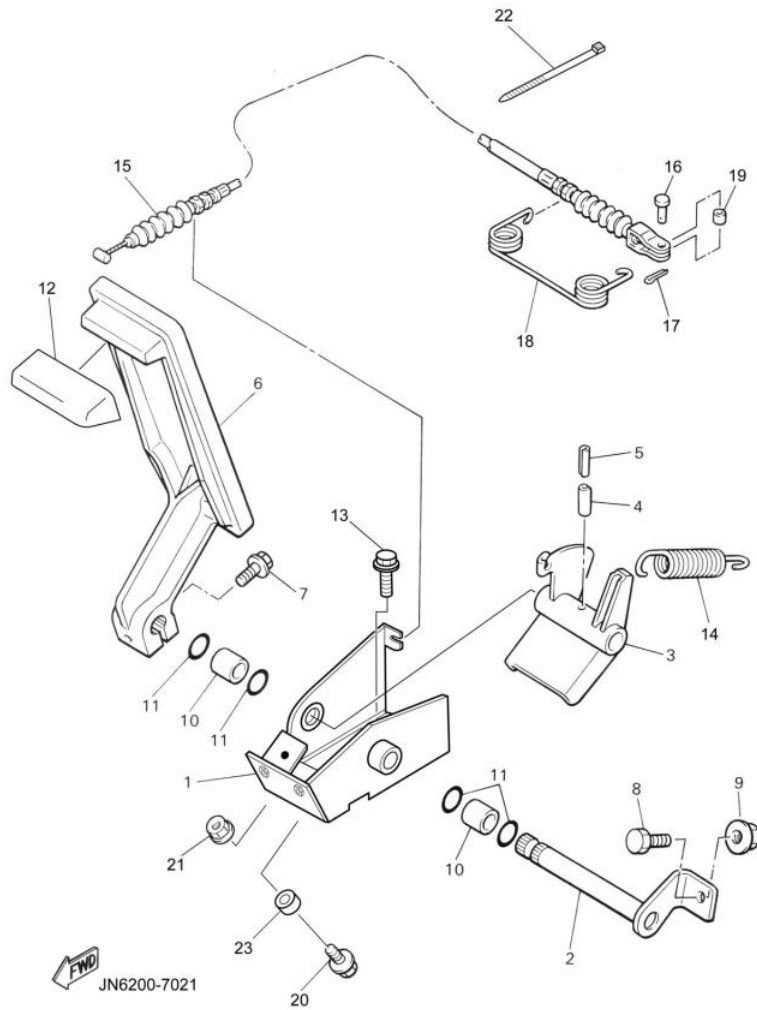
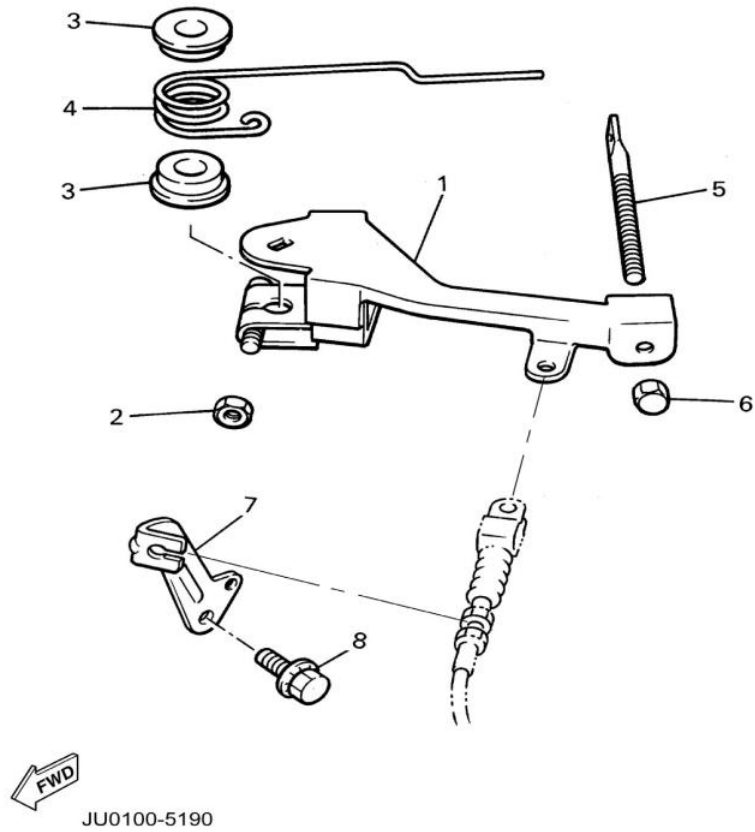

REF NO.	PART NUMBER	DESCRIPTION	QTY	REMARKS
1	J38-27951-00-00	LEVER, SPEED	1	
2	95317-06600-00	NUT, HEX.	1	
3	90386-08141-00	BUSH	2	
4	90508-40678-00	SPRING, TORSION	1	
5	J38-27959-00-00	SCREW, ADJUSTING	1	
6	95607-06200-00	NUT, U-FLANGE	1	
7	JN3-G6555-00-00	BRACKET 2	1	
8	90105-08859-00	BOLT, FLANGE	1	

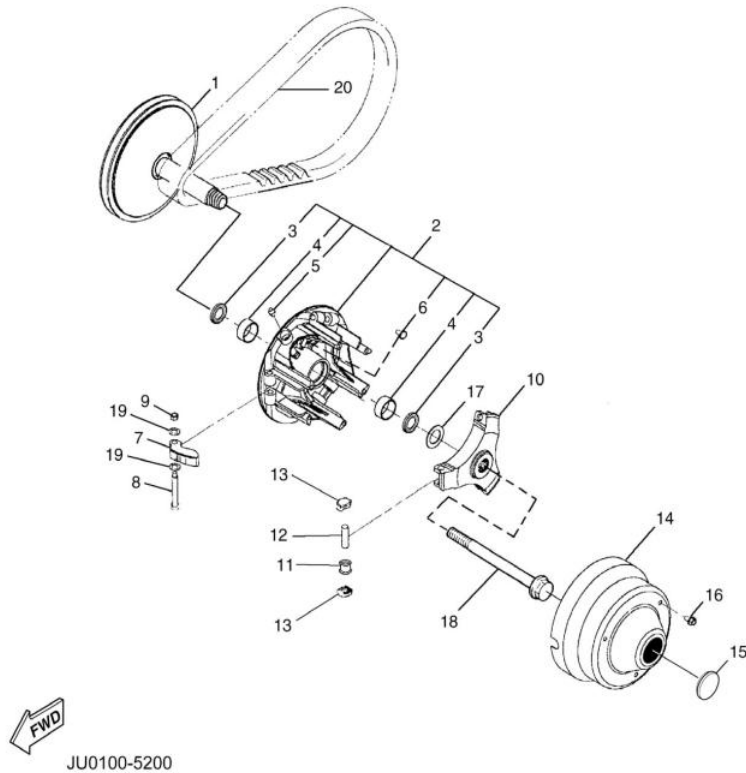

FIG. 21 PRIMARY CLUTCH

REF NO.	PART NUMBER	DESCRIPTION	QTY	REMARKS
	JN6-G6201-04-00	PRIMARY CLUTCH ASSEMBLY	1	SEE NOTE "A"
1	JN6-G6210-00-00	PRIMARY FIXED SHEAVE	1	
2	JN6-G6221-00-00	PRIMARY SLIDING SHEAVE	1	
3	93101-28831-00	. SEAL, OIL	2	
4	90384-27823-00	. BUSH, BIMETAL FORMED	2	
5	93700-06810-00	. NIPPLE, GREASE	1	
6	90338-04840-00	. PLUG	3	
7	JN6-G6232-01-00	WEIGHT, 1	3	
8	90109-06860-00	BOLT	3	
9	90185-06834-00	NUT, SELF-LOCKING	3	
10	JN6-G6251-01-00	SPIDER	1	SEE NOTE "B"
11	JN6-G6258-02-00	COLLAR, ROLLER	3	SEE NOTE "B"
12	93610-358A3-00	PIN, DOWEL	3	
13	JN6-G6253-00-00	SLIDER	6	
14	JU0-G6231-00-00	CAP	1	
15	JU0-G6297-00-00	COVER, DUST	1	
16	90105-06861-00	BOLT, FLANGE	3	
17	90201-228K5-00	WASHER, PLAIN	1	
18	JN6-G6249-00-00	BOLT	1	
19	JN6-G621F-00-00	SHIM, THRUST	6	
20	J55-G6241-00-00	BELT	1	

NOTE "A": Assembly includes all parts except REF. Numbers 18 and 20 (the main bolt for the Primary Clutch assembly and the belt.)

NOTE "B": Old style Spider and Collar/Rollers are no longer available. Order Spider/Roller Kit pn JU0-G6430-00-00 to upgrade older units (serial number JR6-300301 and earlier), see Technical Bulletin G03-005. Serial number JR6-300302 and later were manufactured with NEW spider & rollers.

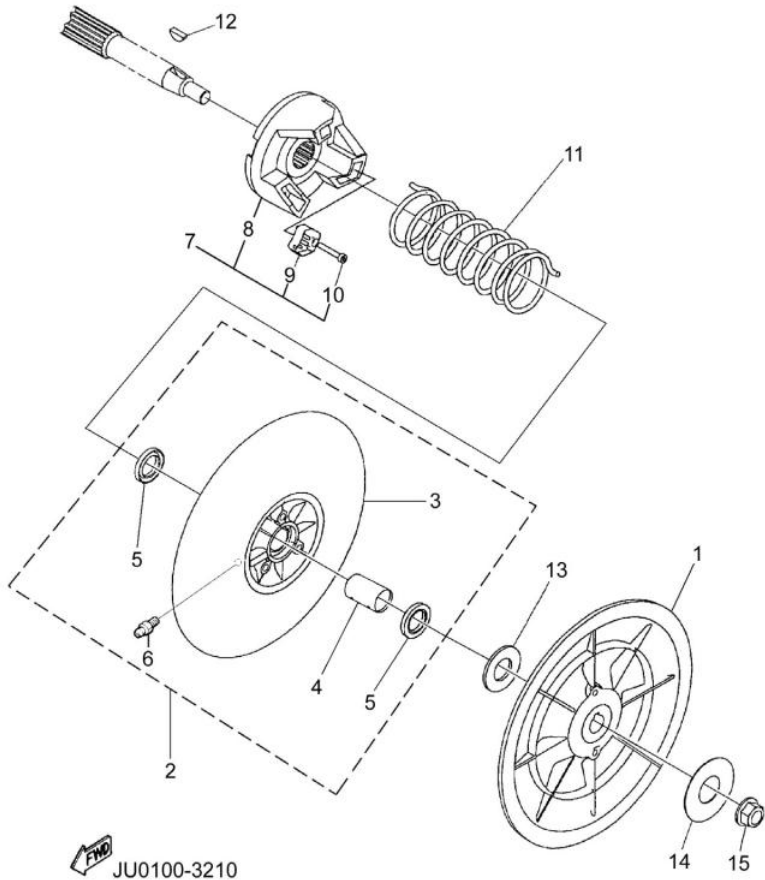

FIG. 22 SECONDARY SHEAVE

REF NO.	PART NUMBER	DESCRIPTION	QTY	REMARKS
1	JN6-G6260-00-00	SECONDARY FIXED SHEAVE	1	
2	JN6-G6270-01-KT	SECONDARY SLIDING SHEAVE KIT	1	SEE NOTE "A"
3	JN6-G6271-02-00	. SECONDARY SLIDING SHEAVE	1	
4	90384-20824-00	. BUSHING, BIMETAL FORMED	1	
5	93109-20069-00	. SEAL, OIL	2	
6	93700-06809-00	. NIPPLE, GREASE	1	
7	JN6-G6280-00-00	SECONDARY SPRING SEAT COMP.	1	SEE NOTE "B"
8	JN6-G6284-00-00	. SECONDARY SPRING SEAT	1	
9	JN6-E7688-00-00	. SHOE, RAMP	3	
10	90110-04834-00	. BOLT, HEX. SOCKET	3	
11	90508-45849-00	SPRING, TORSION	1	L=135.0mm±1.5
12	90280-05022-00	KEY, WOODRUFF	1	
13	90202-20130-00	WASHER, PLAIN	1	
14	90201-12588-00	WASHER, PLAIN	1	
15	95607-12200-00	NUT, U-FLANGE	1	

NOTE "A": Secondary sheave kit Includes: secondary sliding sheave, bushing, oil seals and grease nipple.

NOTE "B": Secondary spring seat comp. Includes: secondary spring seat, shoe ramp and bolts.

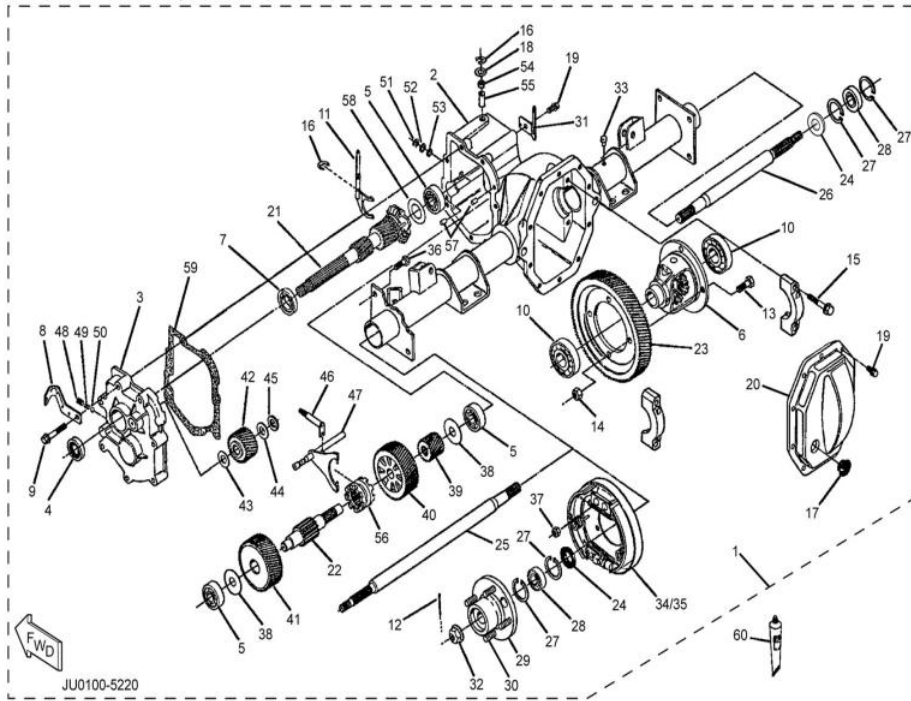

FIG. 23 TRANSMISSION 1

REF NO.	PART NUMBER	DESCRIPTION	QTY	REMARKS
1	JR6-G6300-02-00	TRANSAXLE ASSEMBLY	1	
2	JR3-G6290-02-00	. CASE ASSY	1	
3	JN3-G6313-00-00	. COVER, TRANSMISSION	1	
4	93102-25868-00	. SEAL, OIL	1	
5	93306-303Y6-00	. BEARING	3	
6	JN6-G6410-00-00	. DIFFERENTIAL ASSY.	1	
7	93306-005Y4-00	. BEARING	1	
8	JN6-G6555-00-00	. BRACKET, 2	1	
9	90105-08859-00	. BOLT, FLANGE	7	
10	93306-007Y0-00	. BEARING	2	
11	JN3-G633E-01-00	. BAR, 1	1	
12	90252-36801-00	. PIN, SPLIT	2	
13	90101-10854-00	. BOLT, HEX.	4	
14	90170-10840-00	. NUT, HEX.	4	
15	90105-10840-00	. BOLT, FLANGE	4	
16	JU0-F722H-00-00	. RETAINER	2	
17	JN3-G6432-00-00	. STOPPER	1	
18	JU0-F723F-00-00	. WASHER, SPECIAL 1	1	
19	90101-08856-00	. BOLT, HEX.	11	
20	JN3-G6314-00-00	. COVER, TRANSMISSION 2	1	
21	JR6-G6320-01-00	. SHAFT, INPUT ASSY.	1	
22	JN3-G633G-00-00	. SHAFT	1	
23	JN3-G6355-00-00	. GEAR, PRIMARY	1	
24	93101-31836-00	. SEAL, OIL	2	
25	JR3-G6511-00-00	. SHAFT, RR. AXLE 1	1	
26	JR3-G6512-00-00	. SHAFT, RR. AXLE 2	1	
27	93420-52806-00	. CIRCLIP	4	

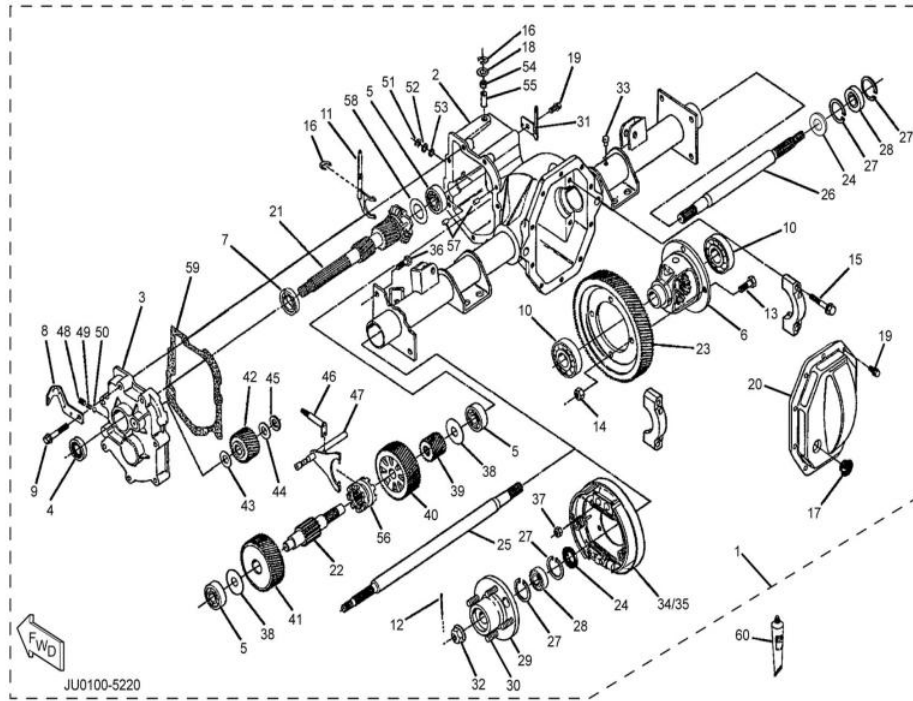

FIG. 23 TRANSMISSION 1

REF NO.	PART NUMBER	DESCRIPTION	QTY	REMARKS
28	93306-205X2-00	.BEARING	2	
29	JR3-G6514-00-00	. HUB, RR. AXLE	2	
30	90114-12804-00	. BOLT, KNURLED	8	
31	JN3-G6556-00-00	. BRACKET, 3	1	
32	90185-19842-00	. NUT, SELF-LOCKING	2	
33	JH7-G5619-00-00	. CAP	1	
34	JN6-F7290-03-00	. BACKING PLATE ASSY. LH	1	
35	JN6-F7280-03-00	. BACKING PLATE ASSY. RH	1	
36	90101-08855-00	. BOLT, HEX.	8	
37	90170-08841-00	. NUT, HEX.	8	
38	90201-178H8-00	. WASHER, PLAIN	2	
39	JN3-G6316-00-00	. GEAR, PINION 1	1	
40	JR6-G6326-00-00	. GEAR, WHEEL 1	1	
41	JN3-G6327-00-00	. GEAR, WHEEL 2	1	
42	JN3-G6356-00-00	. GEAR, IDLER	1	
43	90201-208H9-00	. WASHER, PLAIN	1	
44	90201-208J0-00	. WASHER, PLAIN	1	
45	93440-20813-00	. CIRCLIP	1	
46	JN3-G638A-00-00	. BAR, SHIFT 1	1	
47	JN6-G638E-00-00	. BAR, SHIFT 2	1	
48	90113-08803-00	. BOLT, SET	1	
49	90501-10852-00	. SPRING, COMPRESSION	1	
50	93500-06826-00	. BALL	1	
51	93410-12822-00	. CIRCLIP	1	
52	90202-12807-00	. WASHER, PLAIN	1	
53	93104-11829-00	. SEAL, OIL	1	
54	93109-10820-00	. SEAL, OIL	1	

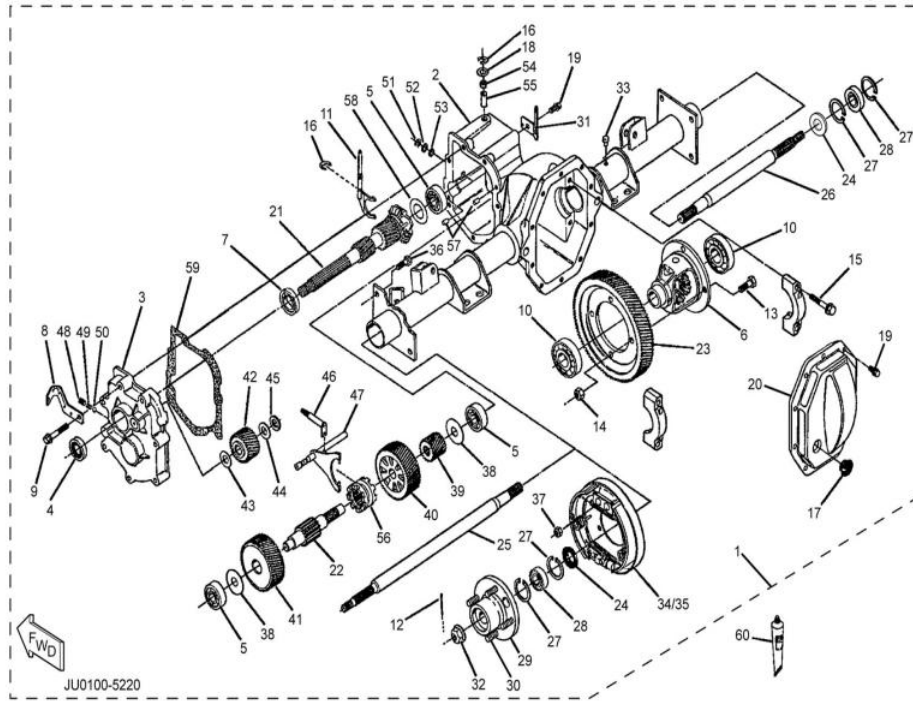
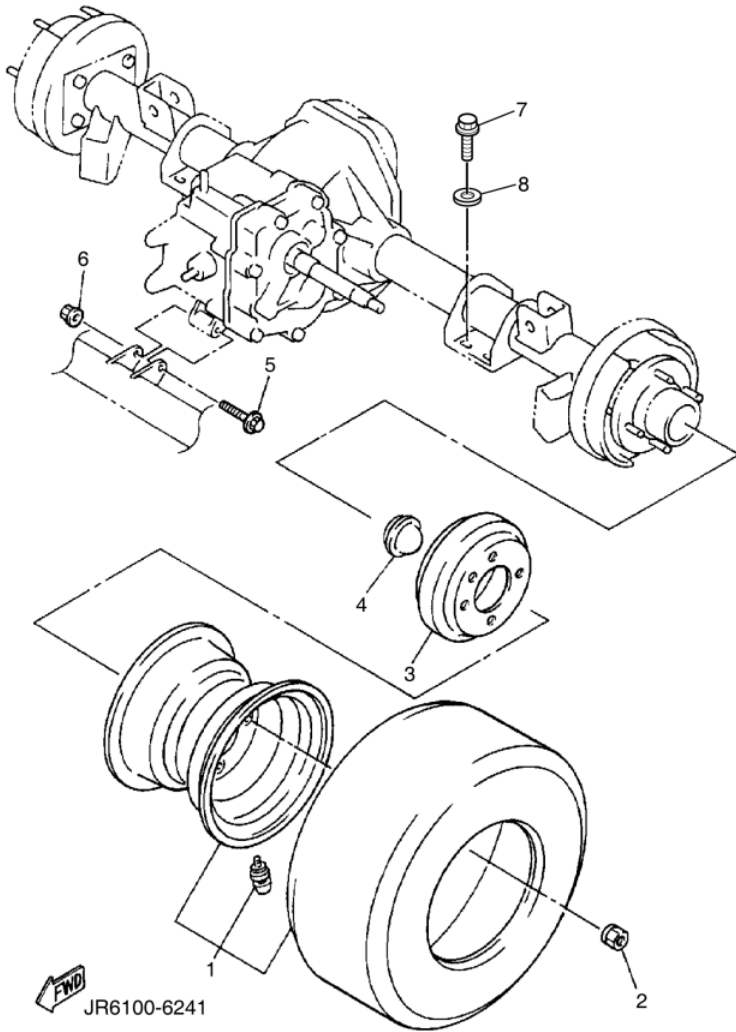

FIG. 23 TRANSMISSION 1

REF NO.	PART NUMBER	DESCRIPTION	QTY	REMARKS
55	JU0-G6164-00-00	. GOVERNOR BUSHING	1	
56	JN3-G6153-00-00	. COLLAR, GUIDE	1	
57	93606-10842-00	. PIN, DOWEL	2	
58	JN3-G6344-00-00	. SHIM	1	0.76mm (0.030in)
	JN3-G6344-10-00	. SHIM	1	0.90mm (0.035in)
	JN3-G6344-20-00	. SHIM	1	1.0mm (0.040in)
	JN3-G6344-30-00	. SHIM	1	1.14mm (0.045in)
	JN3-G6344-40-00	. SHIM	1	1.27mm (0.050in)
	JN3-G6344-50-00	. SHIM	1	1.39mm (0.055in)
	JN3-G6344-60-00	. SHIM	1	1.52mm (0.060in)
	JN3-G6344-70-00	. SHIM	1	1.65mm (0.065in)
	JN3-G6344-80-00	. SHIM	1	0.38mm (0.015in)
	JN3-G6344-90-00	. SHIM	1	1.78mm (0.070in)
	JN3-G6344-A0-00	. SHIM	1	1.92mm (0.075in)
	JN3-G6344-B0-00	. SHIM	1	2.03mm (0.080in)
	JN3-G6344-C0-00	. SHIM	1	2.12mm (0.085in)
	JN3-G6344-D0-00	. SHIM	1	2.29mm (0.090in)
59	JN3-G6319-00-00	. GASKET	1	
60	ACC-QUICK-GS-KT	SEALANT 1	1	

FIG. 24 REAR AXLE MOUNT / WHEEL



REF NO.	PART NUMBER	DESCRIPTION	QTY	REMARKS
1	JR6-F5300-00-00	WHEEL ASSY.	2	
2	90179-12262-00	NUT	8	
3	J55-G6521-10-00	DRUM	2	
4	JN6-F5118-00-00	COVER, HUB DUST	2	
5	95817-08075-00	BOLT, FLANGE	1	
6	90179-08491-00	NUT, FLANGE	1	
7	9751P-10420-00	BOLT, HEX. HEAD W/WASHER	8	
8	90201-108S3-00	WASHER PLAIN	8	

FIG. 25 SHIFTER / CABLES

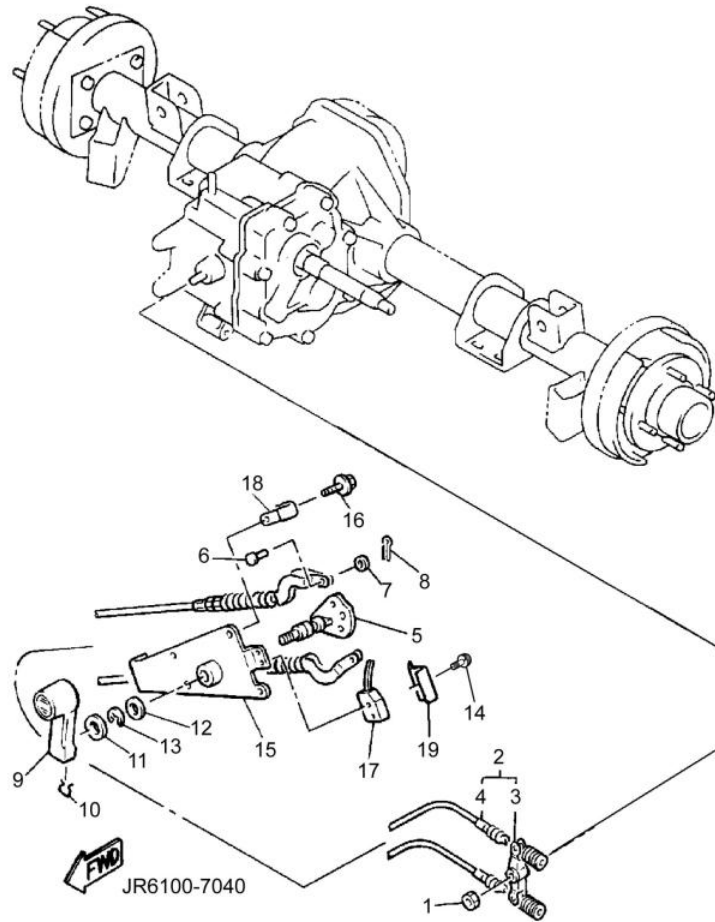

REF NO.	PART NUMBER	DESCRIPTION	QTY	REMARKS
1	95617-08100-00	NUT, U	1	
2	JJ3-G8330-01-00	SHIFT CABLE END ASSY.	1	
3	J55-G6383-00-00	. LEVER, SHIFT 2	1	
4	JJ3-G6371-01-00	. WIRE, SHIFT	2	
5	JF2-46382-00-00	LEVER, SHIFT 1	1	
6	91701-06014-00	PIN	2	
7	92907-06600-00	WASHER, PLAIN	2	
8	91490-20015-00	PIN, SPLIT	2	
9	JN3-G6381-00-00	KNOB, SHIFT	1	
10	JN3-G6376-00-00	SPRING SET	1	
11	90201-201L9-00	WASHER, PLAIN	1	
12	90201-19551-00	WASHER, PLAIN	1	
13	99009-19400-00	CIRCLIP (S)	1	
14	97607-04325-00	SCREW, PANHEAD W/WASHER	2	
15	JN3-G6372-00-00	BRACKET, SHIFT WIRE	1	
16	90105-06876-00	BOLT, FLANGE	4	
17	JN3-82617-00-00	SWITCH	1	
18	90465-06038-00	CLAMP	1	
19	JJ3-G6394-00-00	JOINT	1	

FIG. 26 BUMPER

REF NO.	PART NUMBER	DESCRIPTION	QTY	REMARKS
1	JN3-K7510-02-00	FRONT BUMPER COMP.	1	
2	JN8-K8164-00-00	STAY, FR. BUMPER	2	
3	95817-06016-00	BOLT, FLANGE	4	
4	9581P-08016-00	BOLT, FLANGE	2	

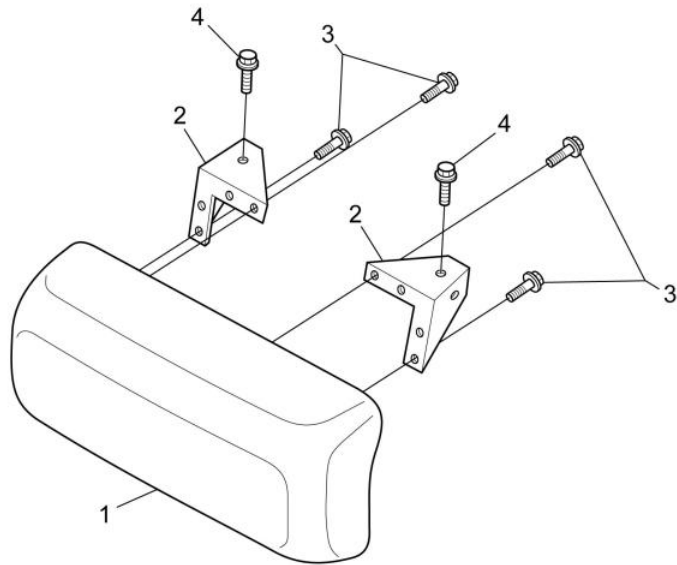

JR6100-5240

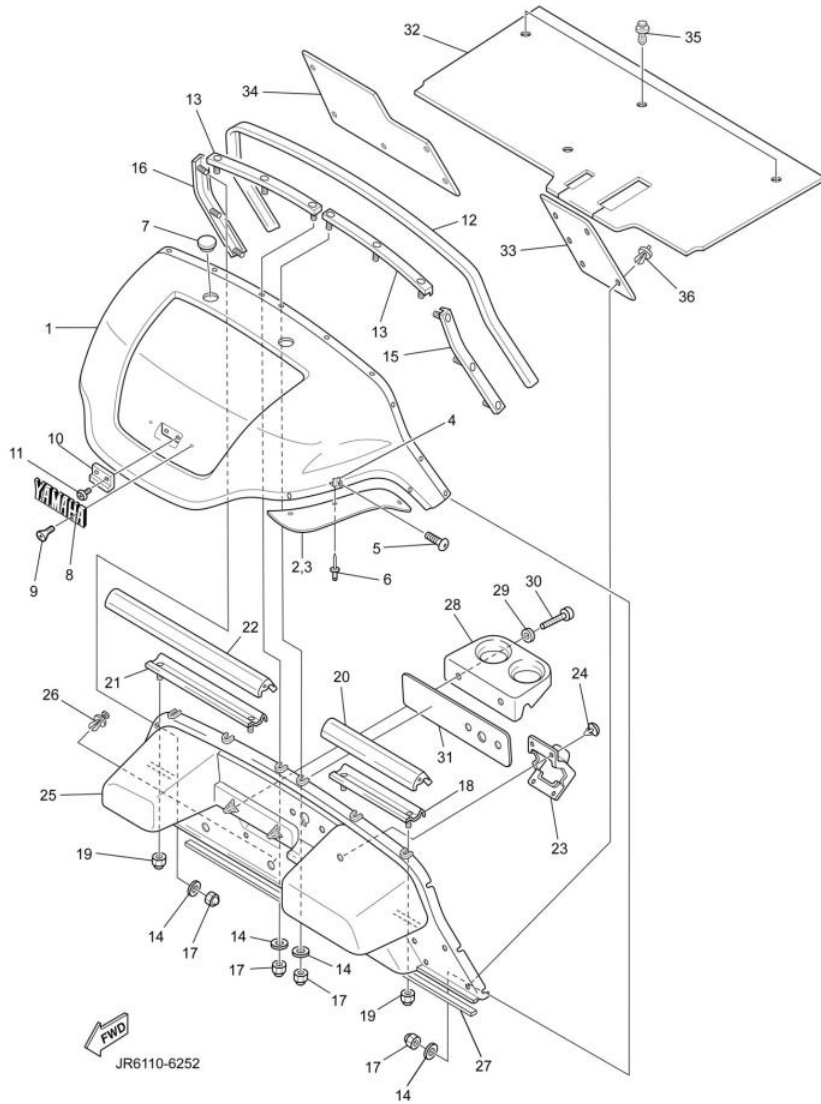

FIG. 27 BODY

REF NO.	PART NUMBER	DESCRIPTION	QTY	REMARKS
1	JN3-K8115-51-00	COWL, FRONT	1	HUNTER GREEN
2	JR6-F1551-00-00	FENDER OVER 1	1	
3	JR6-F1555-00-00	FENDER OVER 2	1	
4	JR6-F1546-00-00	STAY, FENDER 3	6	
5	90110-06836-00	BOLT, HEX SOCKET	6	
6	90267-48831-00	RIVET, BLIND	6	
7	JN3-K818E-00-00	CAP, PROTECTOR	2	
8	JN6-F4161-01-00	EMBLEM, 1	1	
9	90162-04002-00	SCREW, OVAL COUNTERSUNK TAP	2	
10	JF2-K811G-00-00	BOLT, COWL FITTING	1	
11	98980-06016-00	SCREW, BINDING	2	
12	JF2-K811V-00-00	PROTECTOR, 1	1	
13	JF2-K8261-02-00	PLATE, BODY PROTECTOR 1	2	
14	90201-06840-00	PLATE, 1	12	
15	JF2-K8262-01-00	PLATE, BODY PROTECTOR 2	1	
16	JF2-K8263-01-00	PLATE, BODY PROTECTOR 3	1	
17	90185-06836-00	NUT, SELF-LOCKING	12	
18	JF2-K8264-00-00	PLATE, BODY PROTECTOR 4	1	
19	9560P-06200-00	NUT, U-FLANGE	2	
20	JF2-K811W-00-00	PROTECTOR 2	1	
21	JF2-K8265-00-00	PLATE, BODY PROTECTOR	1	
22	JF2-K811X-00-00	PROTECTOR 3	1	
23	JF2-78273-00-00	COVER, HOLE 1	1	
24	90269-11042-00	RIVET	4	
25	JF2-K8114-03-00	PANEL, FRONT	1	SEE NOTE "A"
26	90269-08069-00	RIVET	3	
27	JN3-K815G-00-00	SEAL, FRONT STORAGE	1	

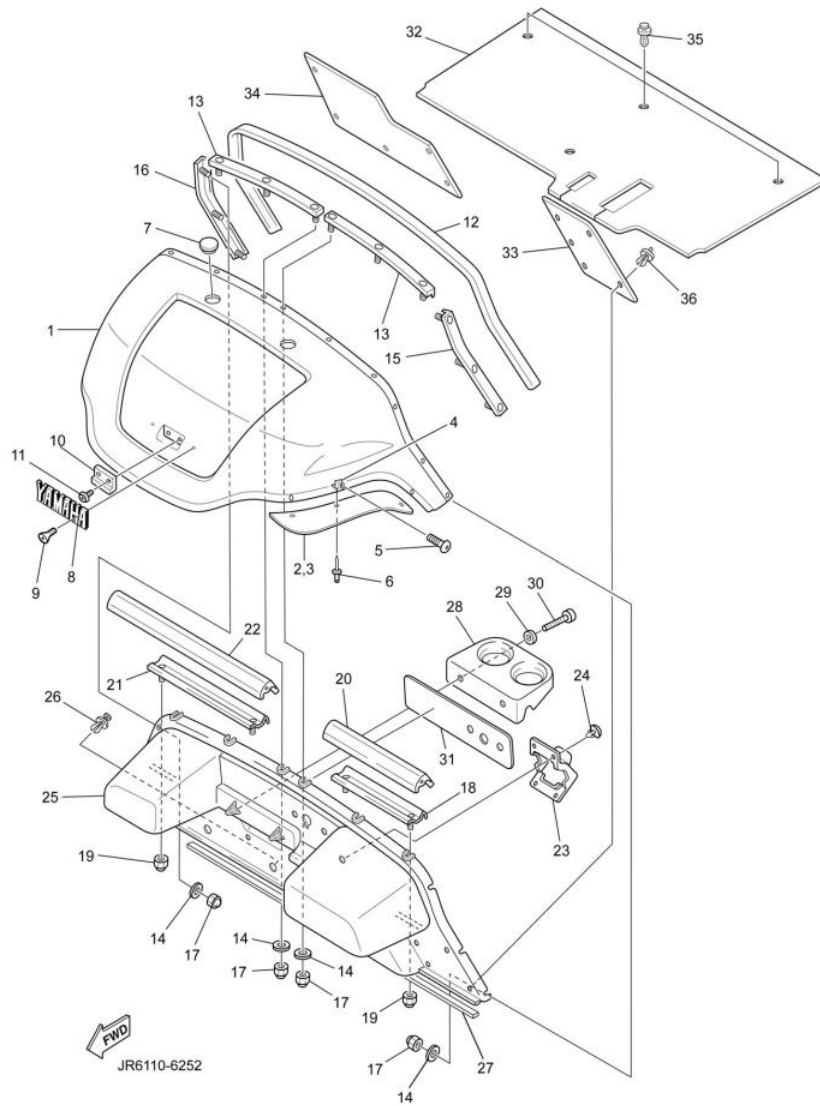
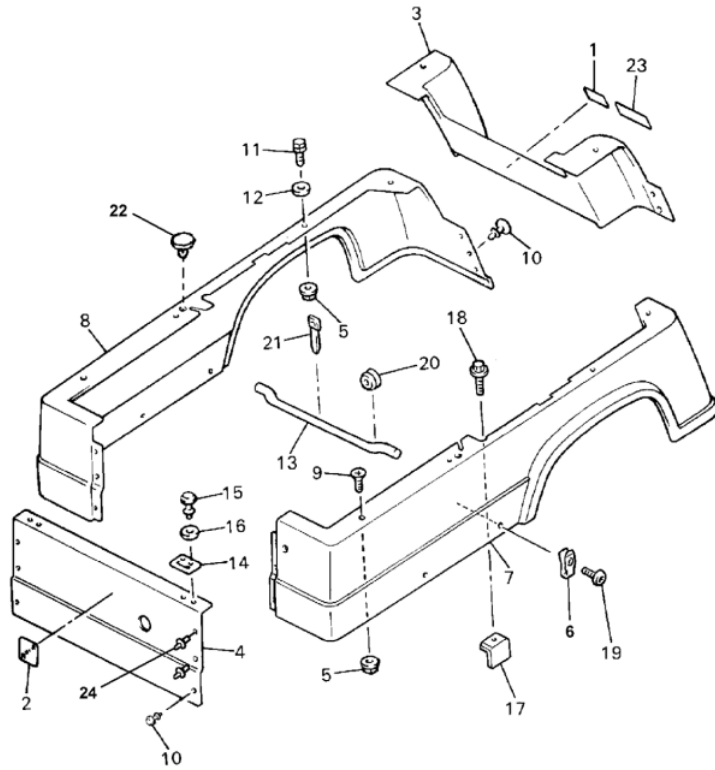

FIG. 27 BODY

REF NO.	PART NUMBER	DESCRIPTION	QTY	REMARKS
28	JF2-K835E-00-00	HOLDER, BEVERAGE	1	
29	90201-068R6-00	WASHER, PLATE	2	
30	97707-60130-00	SCREW, TAPPING	2	
31	JR6-K7761-00-00	LABEL, WARNING 1	1	
32	JN6-K8233-01-00	MAT, MAIN FLOOR 3	1	
33	JN6-K8231-01-00	MAT, MAIN FLOOR 1	1	
34	JN6-K8232-01-00	MAT, MAIN FLOOR 2	1	
35	90269-08813-00	RIVET	4	
36	90267-63047-00	RIVET, BLIND	9	

NOTE "A": When replacing "Panel Front JF2-K8114-03-00" you should also replace "Label Warning 1 JR6-K7761-00-00".

FIG. 28 BODY 2



 JJ3110-6261

REF NO.	PART NUMBER	DESCRIPTION	QTY	REMARKS
1	JJ3-K7765-00-00	LABEL, WARNING 5	1	SEE NOTE "A"
2	JN3-K7741-00-00	INDICATOR 1	1	SEE NOTE "B"
3	JJ3-K8142-50-00	PANEL, REAR BODY	1	HUNTER GREEN, SEE NOTE "A"
4	JJ3-K8141-50-00	PANEL, INTERMEDIATE BODY	1	HUNTER GREEN, SEE NOTE "B"
5	90183-06810-00	NUT, SPRING	10	
6	90183-06811-00	NUT, SPRING	4	
7	JJ3-K8111-51-00	PANEL, BODY SHELL	1	HUNTER GREEN
8	JJ3-K8112-51-00	PANEL, BODY SHELL	1	HUNTER GREEN
9	98780-06020-00	SCREW, COUNTERSUNK	2	
10	90267-62841-00	RIVET, BLIND	6	
11	90119-06837-00	BOLT, HEX. W/WASHER	8	
12	90201-068R8-00	WASHER, PLATE	8	
13	JJ3-K8226-00-00	ROD, SEAT STOPPER	1	
14	JJ3-K8427-01-00	HINGE, SEAT 2	2	
15	90267-64834-00	RIVET, BLIND	4	
16	90201-088S1-00	WASHER, PLATE	4	
17	JJ3-K814H-00-00	HOOK, BODY LOCK	2	
18	90119-08800-00	BOLT, HEX. W/WASHER	2	
19	90110-06836-00	BOLT, HEXAGON SOCKET HEAD	4	
20	90480-13018-00	GROMMET	1	
21	90464-10814-00	CLAMP	1	
22	4XE-F4747-00-00	BUMPER, RUBBER 1	2	
23	JJ3-K7768-00-00	LABEL, WARNING 8	1	SEE NOTE "A"
24	90267-36853-00	RIVET, BLIND	4	

NOTE "A": When replacing "Panel Rear Body JJ3-K8142-50-00" you must also replace "Label Warning 5 JJ3-K7765-00-00", and "Label Warning 8 JJ3-K7768-00-00".

NOTE "B": When replacing "Panel Intermediate Body JJ3-K8141-50-00" you must also replace "Indicator 1 JN3-K7741-00-00".

FIG. 29 BODY FITTING

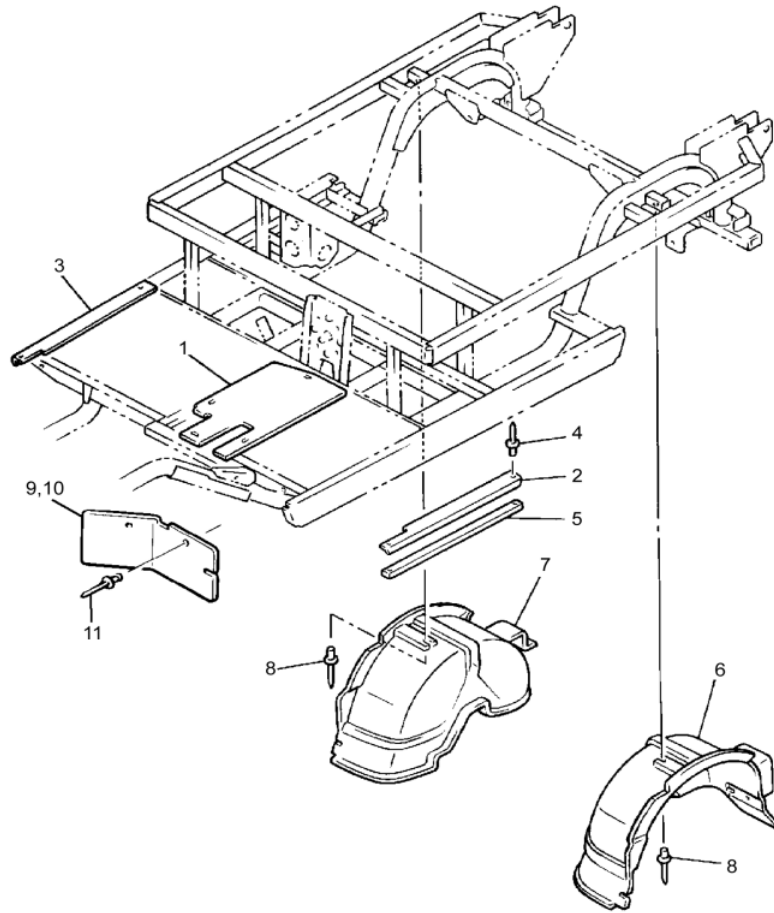

REF NO.	PART NUMBER	DESCRIPTION	QTY	REMARKS
1	JN6-K8271-00-00	SERVICE LID	1	
2	JF2-K8215-10-00	PLATE, SIDE TRIM	1	
3	JF2-K821F-10-00	PLATE, SIDE TRIM 2	1	
4	90267-48154-00	RIVET, BLIND	4	
5	JJ3-K8124-00-00	REINFORCEMENT 4	2	
6	JJ3-K8191-00-00	PANEL, REAR FENDER 1	1	
7	JJ3-K8192-00-00	PANEL, REAR FENDER 2	1	
8	90267-48831-00	RIVET, BLIND	6	
9	JF2-K8187-00-00	FLAP, FRONT FENDER LEFT	1	
10	JF2-K8189-00-00	FLAP, FRONT FENDER RIGHT	1	
11	90267-48831-00	RIVET, BLIND	4	

 JR3100-7060

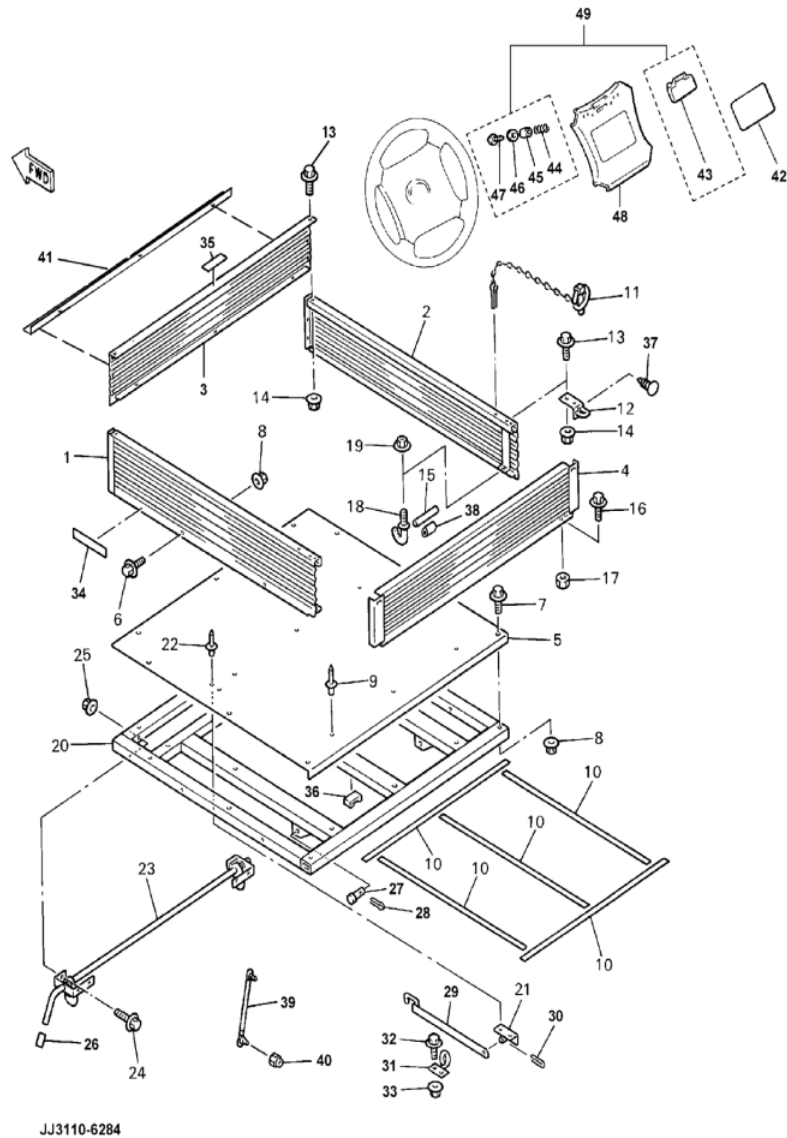

FIG. 30 CARRIER

REF NO.	PART NUMBER	DESCRIPTION	QTY	REMARKS
1	JJ3-K810F-00-00	SIDE PANEL COMP. (LH)	1	SEE NOTE "A"
2	JJ3-K810G-00-00	SIDE PANEL COMP. (RH)	1	
3	JJ3-K7782-00-00	PANEL, DASH 2	1	SEE NOTE "B"
4	JJ3-K810N-01-00	REAR STORAGE LID COMP.	1	
5	JJ3-K8117-00-00	PLATE 1	1	
6	90119-08808-00	BOLT, WITH WASHER	19	
7	90119-08806-00	BOLT, WITH WASHER	2	
8	9560P-08200-00	NUT, SELF-LOCKING	21	
9	90267-64844-00	RIVET, BLIND	6	
10	JJ3-K821A-00-00	PAD, BODY MOUNTING 1	5	
11	JR3-K8156-00-00	STOPPER, LOCK	2	
12	JJ3-K8317-01-00	RING, HOOK	2	
13	90119-06830-00	BOLT, HEX. W/WASHER	6	
14	95607-06200-00	NUT, U FLANGE	6	
15	JJ3-K8384-00-00	BOLT, 1	2	
16	97017-06020-00	BOLT, HEX.	4	
17	9538R-06700-00	NUT, HEX.	4	
18	JJ3-K8385-01-00	BOLT 2	2	
19	9560P-08200-00	NUT, U FLANGE	2	
20	JJ3-K818N-01-00	BED, BOX	1	
21	JJ3-K8376-00-00	SUPPORT 2	1	
22	90267-64844-00	RIVET, BLIND	2	
23	JJ3-K8380-02-00	LOCK ASSY	1	
24	95817-08020-00	BOLT, FLANGE	6	
25	9560P-08200-00	NUT, U FLANGE	6	
26	JJ3-K818M-00-00	CAP, PROTECTOR END 4	1	
27	90240-13808-00	PIN, CLEVIS	2	

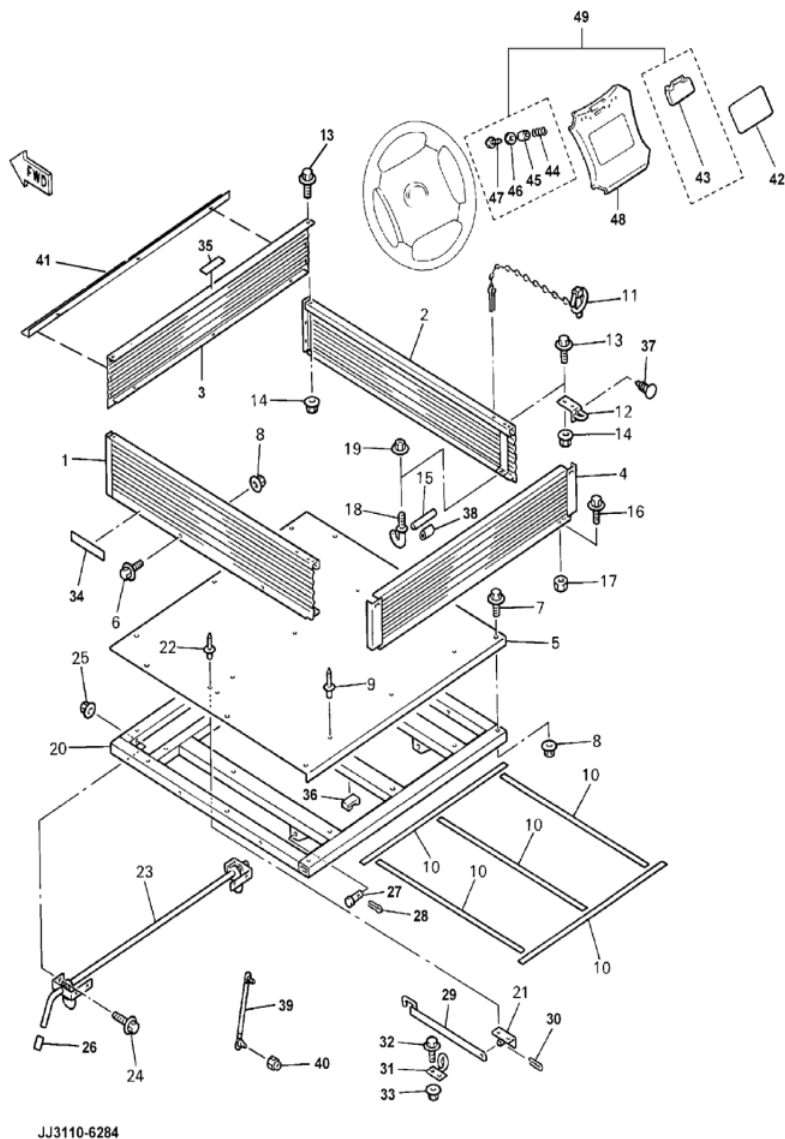

FIG. 30 CARRIER

REF NO.	PART NUMBER	DESCRIPTION	QTY	REMARKS
28	91490-30030-00	PIN, COTTER	2	
29	JJ3-K8158-01-00	ROD, INSPECTION LID	1	
30	91490-20025-00	PIN, COTTER	1	
31	JJ3-K8369-00-00	PIN, LEVER	1	
32	90119-06830-00	BOLT, WITH WASHER	2	
33	95607-06200-00	NUT, SELF-LOCKING	2	
34	JJ3-K7764-01-00	LABEL, WARNING 4	1	SEE NOTE "A"
35	JJ3-K7766-01-00	LABEL, WARNING 6	1	SEE NOTE "B"
36	JJ3-K815H-01-00	DAMPER, LOCK	3	
37	90338-05830-00	PLUG	4	
38	JR3-K8316-00-00	DAMPER	2	
39	JJ3-K7588-00-00	DAMPER 1	1	
40	9560P-08200-00	NUT, SELF-LOCKING	2	
41	JR3-K8323-00-00	BRACKET, 1	1	
42	JN3-K7762-01-00	LABEL, WARNING 2	1	SEE NOTE "C"
43	JN6-K8358-01-00	HOLDER, 2	1	
44	90502-10013-00	SPRING, CONICAL	2	
45	90387-046N7-00	COLLAR	2	
46	90201-044H9-00	WASHER, PLAIN	2	
47	97707-40625-00	SCREW PAN HEAD	2	
48	JN3-K8357-00-00	HOLDER 1	1	SEE NOTE "C"
49	JN6-K8358-00-KT	INFORMATION HOLDER KIT	1	SEE NOTE "D"

NOTE "A": When replacing "Side Panel Comp. (LH) JJ3-K810F-00-00" you must also replace "Label Warning 4 JJ3-K7764-01-00".

NOTE "B": When replacing "Panel Dash 2 JJ3-K7782-00-00" you must also replace "Label Warning 6 JJ3-K7766-01-00".

NOTE "C": When replacing "Holder 1 JN3-K8357-00-00" you must also replace "Label Warning 2 JN3-K7762-01-00".

NOTE "D": Includes 43, 44, 45, 46, 47

FIG. 31 SEAT

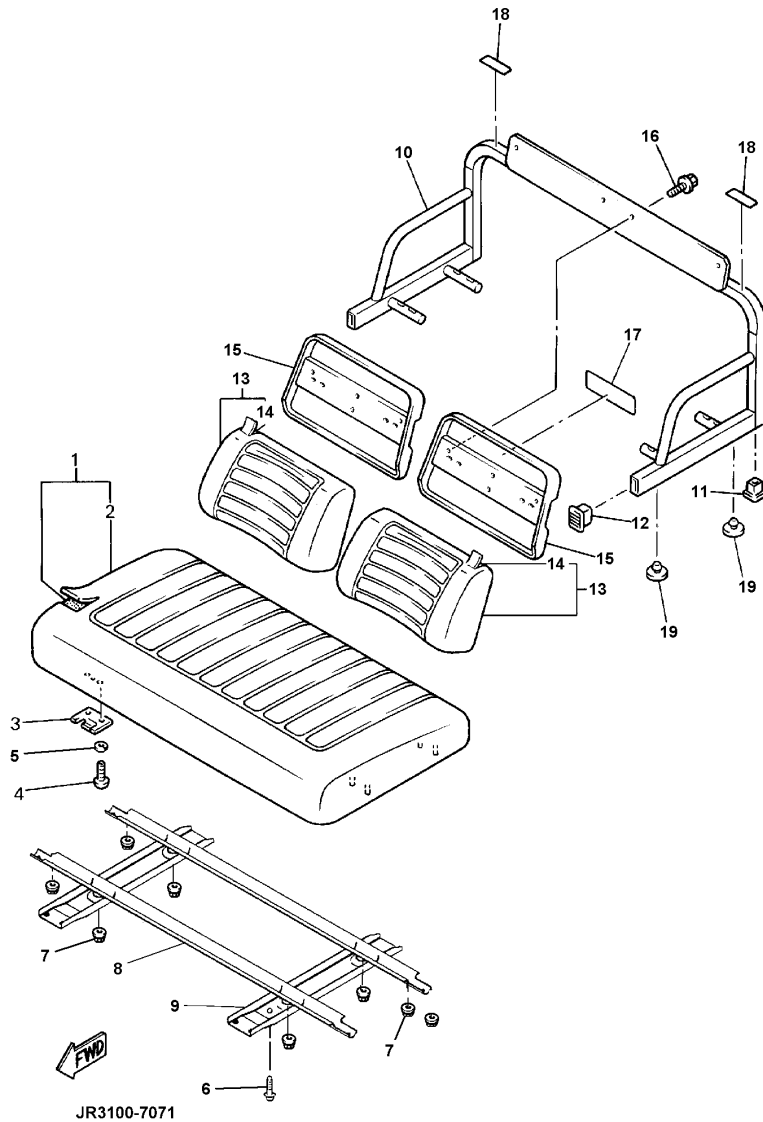

REF NO.	PART NUMBER	DESCRIPTION	QTY	REMARKS
1	JN6-K8401-10-00	CUSHION SEAT	1	
2	JN6-K8404-10-00	. COVER, SEAT	1	
3	JN3-K8426-01-00	HINGE, SEAT MALE	2	
4	90111-06810-00	BOLT, HEX	4	
5	90204-06807-00	WASHER, SPRG.	4	
6	90167-04815-00	SCREW, PAN HEAD TAP	4	
7	9560P-08200-00	NUT, SELF-LOCKING	12	
8	JN6-K8121-00-00	REINFORCEMENT 1	2	
9	JN6-K8122-01-00	REINFORCEMENT 2	2	
10	JJ3-K8420-20-00	SEAT ASSY 2	1	SEE NOTE "A"
11	5FU-F111A-00-00	CAP, MAIN PIPE	2	
12	JJ3-K8139-00-00	CAP, END	2	
13	JR3-K8402-10-00	SEAT SUB ASSY, BACK	2	
14	JR3-K841G-09-00	. COVER, SEAT BACK 2	2	
15	JJ3-K8413-10-00	COVER, SEAT BACK	2	SEE NOTE "B"
16	90119-06837-00	BOLT, HEX. W/WASHER	4	
17	JJ3-K7762-00-00	LABEL, WARNING 2	1	SEE NOTE "B"
18	JJ3-K7763-00-00	LABEL, WARNING 3	2	SEE NOTE "A"
19	JJ3-K8433-01-00	DAMPER, SEAT SUPPORT	4	

NOTE "A": When replacing "Seat Assy 2 JJ3-K8420-20-00" you must also replace "Label Warning 3 JJ3-K7763-00-00".

NOTE "B": When replacing the LS "Cover Seat Back JJ3-K8413-10-00" you must also replace "Label Warning 2 JJ3-K7762-00-00".

FIG. 32 STARTER GENERATOR

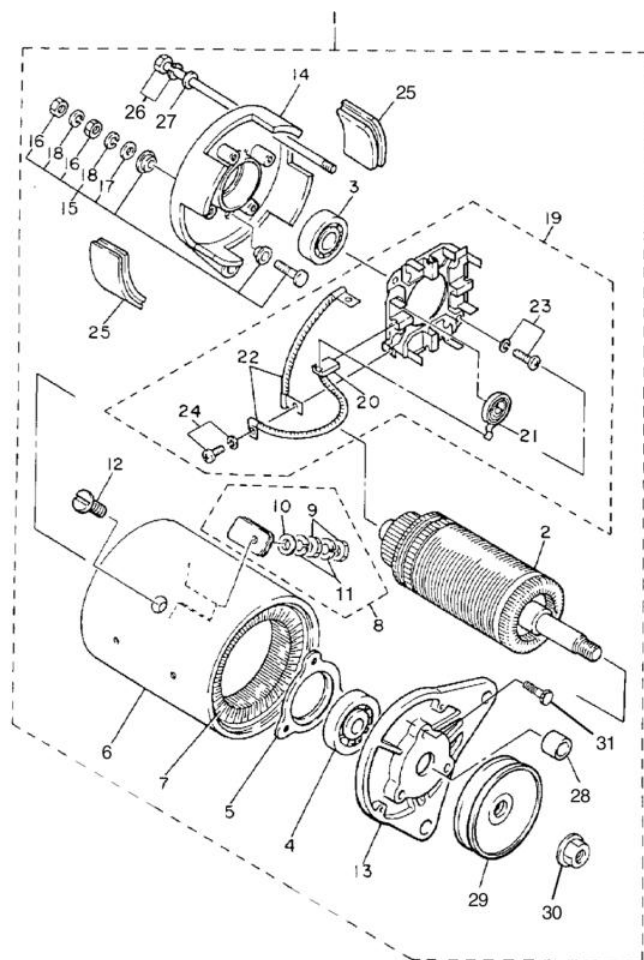

JN6100-6233

REF NO.	PART NUMBER	DESCRIPTION	QTY	REMARKS
1	JN6-H1100-02-00	STARTER GENERATOR	1	
2	JN3-H1150-00-00	.ARMATURE ASSY	1	
3	93306-20226-00	.BEARING 1 (6202 SD)	1	
4	J10-81158-10-00	.BEARING 2 (6203 SD)	1	
5	J10-81159-10-00	.HOLDER, BEARING	1	
6	JN6-H1110-10-00	.STATOR ASSY	1	
7	JN6-H1160-10-00	.FIELD COIL ASSY	1	
8	J10-81148-10-00	.SCREW 4	2	
9	95380-06600-00	.NUT	4	
10	92990-06600-00	.WASHER, WAVE	2	
11	92995-06100-00	.WASHER, WAVE	4	
12	J10-81146-10-00	.SCREW 2	4	
13	J38-81165-10-00	.BRACKET, STARTER GENERATOR 1	1	
14	J10-81166-10-00	.BRACKET, STARTER GENERATOR 2	1	
15	J10-81147-10-00	.SCREW 3	2	
16	95380-06600-00	.NUT	4	
17	92990-06600-00	.WASHER, WAVE	2	
18	92995-06100-00	.WASHER, WAVE	4	
19	JN6-H1119-00-00	.BRUSH HOLDER ASSY	1	
20	JF2-81111-00-00	.BRUSH	4	
21	JN6-H1113-00-00	.SPRING, BRUSH	4	
22	J10-81115-10-00	.WIRE, LEAD	2	
23	98507-05016-00	.SCREW, PAN HEAD	2	
24	98580-04010-00	.SCREW, PAN HEAD	4	
25	J10-81129-10-00	.COVER, BRUSH	4	
26	J10-81145-10-00	.SCREW 1	2	
27	92990-06600-00	.WASHER, PLAIN	2	

FIG. 32 STARTER GENERATOR

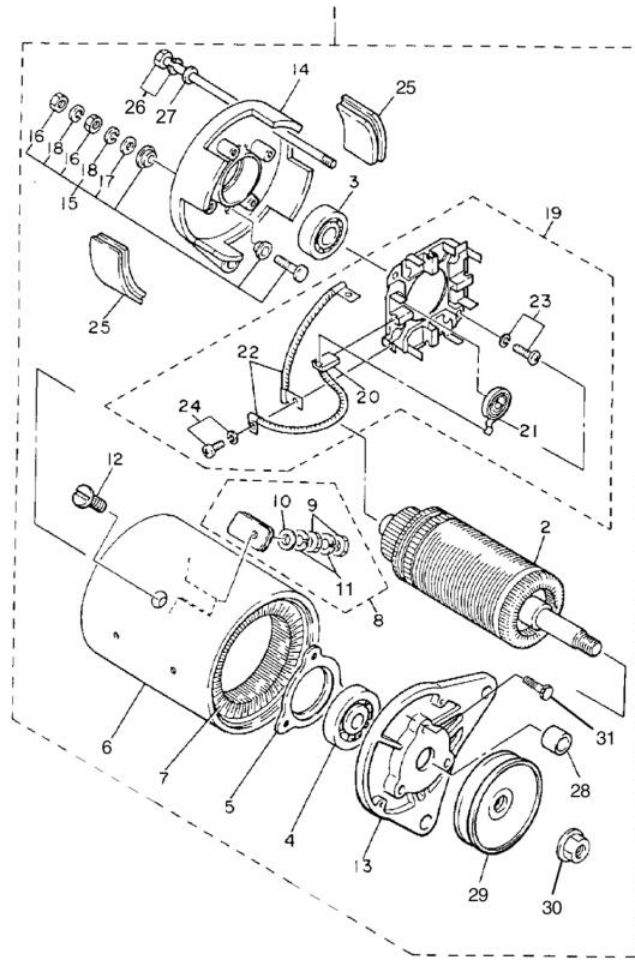

REF NO.	PART NUMBER	DESCRIPTION	QTY	REMARKS
28	JN3-H1661-00-00	.SPACER	1	
29	JN3-H1161-00-00	.PULLEY	2	
30	90179-16889-00	.NUT, FLANGE	1	
31	98507-05018-00	.SCREW	3	



JN6100-6233

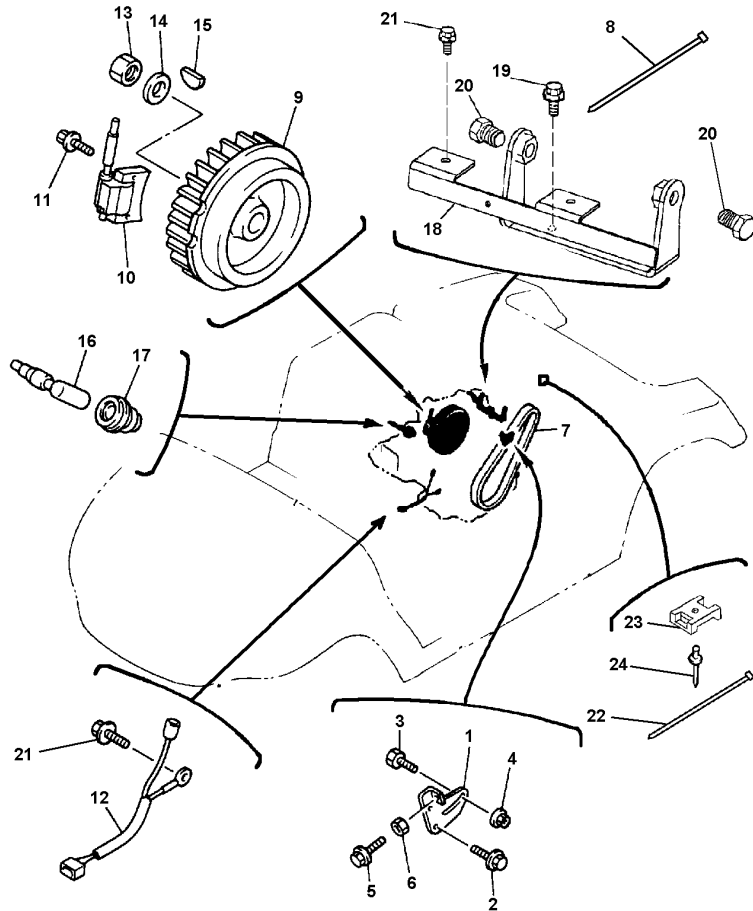

 JN6100-6240

FIG. 33 ELECTRICAL 1

REF NO.	PART NUMBER	DESCRIPTION	QTY	REMARKS
1	JN6-H1170-00-00	TENSIONER ASSY	1	
2	9582P-08020-00	BOLT, FLANGE	2	
3	90109-08875-00	BOLT	1	
4	95707-08500-00	NUT, FLANGE	1	
5	90101-06478-00	BOLT, HEX.	1	
6	95317-06600-00	NUT, HEX.	1	
7	JN6-H1173-00-00	BELT	1	
8	90464-09823-00	CLAMP	1	
9	JR7-85650-00-00	ROTOR ASSY.	1	
10	JN6-85640-01-00	T.C.I. UNIT	1	
11	95817-06025-00	BOLT, FLANGE	2	
12	JN6-82318-00-00	WIRE, SUB-LEAD	1	
13	95307-18600-00	NUT, HEX.	1	
14	90201-18620-00	WASHER, PLAIN	1	
15	90280-04052-00	KEY, WOODRUFF	1	
16	JN6-82370-00-00	PLUG CAP ASSY	1	
17	JE8-82372-00-00	SEAL, PLUG CAP	1	
18	JN6-H1171-00-00	BRACKET, STARTER GENERATOR	1	
19	9582P-08020-00	BOLT, FLANGE	2	
20	9581P-12025-00	BOLT, FLANGE	2	
21	95817-06016-00	BOLT, FLANGE	3	
22	90464-40825-00	CLAMP	3	
23	90207-05800-00	WASHER, FINISH	1	
24	90267-489U9-00	RIVET	1	

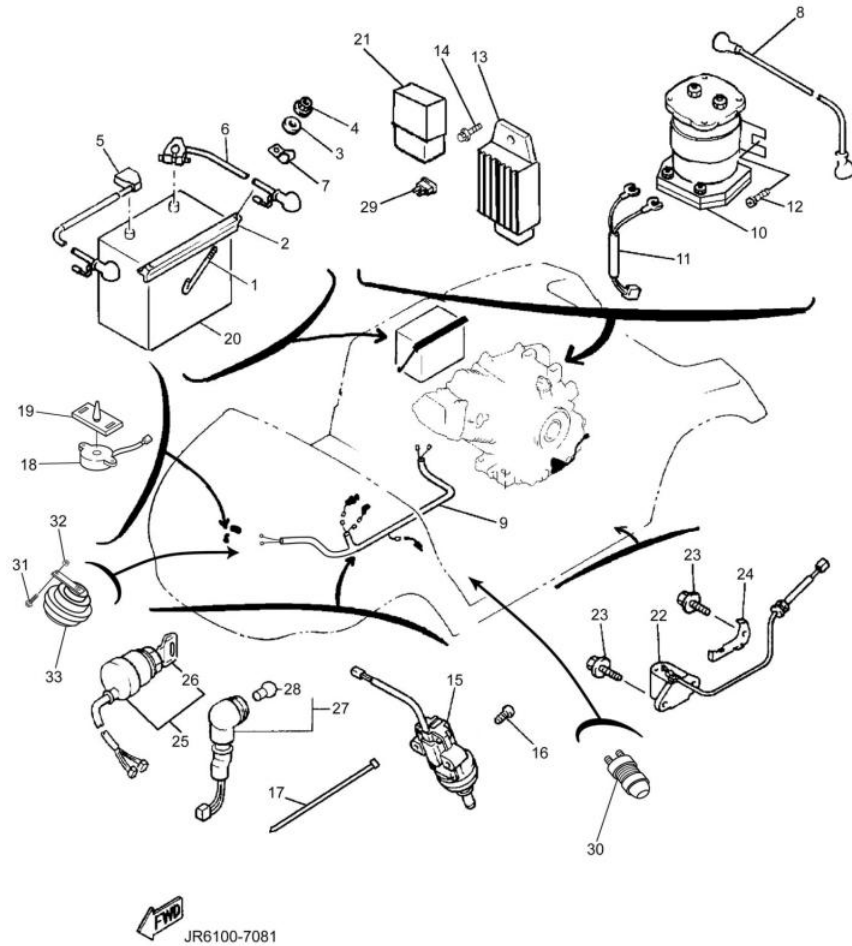
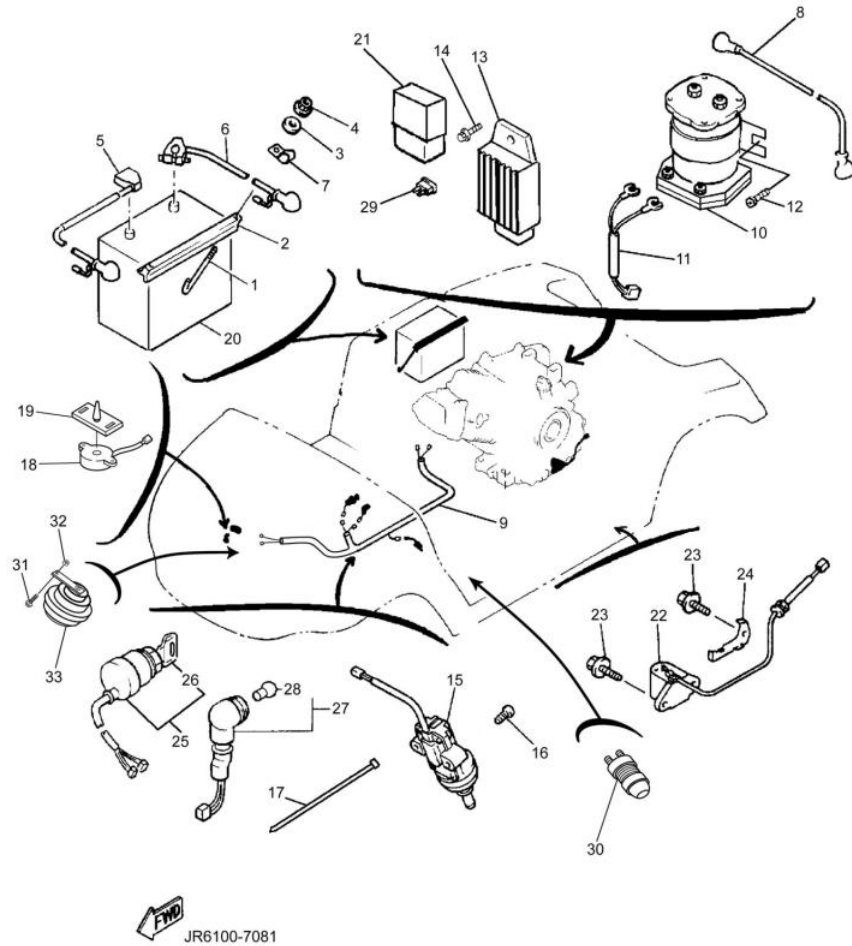

FIG. 34 ELECTRICAL 2

REF NO.	PART NUMBER	DESCRIPTION	QTY	REMARKS
1	JN3-H2133-00-00	SCREW, FITTING	2	
2	J55-H2136-00-00	PLATE, BATTERY FITTING	1	
3	9290P-06200-00	WASHER, PLAIN	2	
4	95707-06500-00	NUT, FLANGE	2	
5	JR3-H2115-01-00	WIRE, PLUS LEAD 1	1	
6	JR3-H2116-00-00	WIRE, MINUS LEAD 2	1	
7	90461-08031-00	CLAMP	2	
8	JR3-H2117-00-00	WIRE, LEAD	1	
9	JR6-H2590-00-00	WIRE HARNESS ASSY.	1	WITH FUSE
10	JR3-H1950-00-00	RELAY ASSY.	1	
11	JN6-H2105-00-00	HARNESS, WIRE	1	
12	90163-06005-00	SCREW, HEX. TAPPING	2	
13	JF2-81910-01-00	VOLTAGE REGULATOR ASSY. 1	1	
14	90105-06876-00	BOLT, FLANGE	1	
15	JF7-82817-20-00	SWITCH, ACCELERATOR STOP	1	
16	97607-05325-00	SCREW, PAN HEAD W/WASHER	2	
17	90464-31827-00	CLAMP	5	
18	JR1-H3383-01-00	BUZZER	1	
19	JN6-H3386-01-00	STAY, BUZZER	1	
20	*	BATTERY - OBTAIN LOCALLY	1	LM (12 V, BCI group 24, CCA: minimum 400A)
21	4U8-81950-02-00	RELAY ASSY.	1	
22	JN6-85720-12-00	OIL LEVEL GAUGE	1	
23	95817-06012-00	BOLT, FLANGE	4	
24	JN6-85724-00-00	CLAMP, OIL LEVEL	1	
25	JN8-82510-02-00	MAIN SWITCH ASSY.	1	
	JN8-82510-09-00	MAIN SWITCH ASSY., RANDOM KEY	1	OPTIONAL SWITCH ASSY
26	J44-82511-00-YY	KEY, MAIN SWITCH	1	FOR STD. MAIN SWITCH ONLY

FIG. 34 ELECTRICAL 2



REF NO.	PART NUMBER	DESCRIPTION	QTY	REMARKS
27	JN6-83530-00-00	PILOT LAMP A	1	
28	123-83516-21-XX	BULB, (12V-3.4W)	1	
29	42X-82151-00-00	FUSE (10A-BLADE)	1	
30	JR6-H270X-00-00	SWITCH, HORN COMP.	1	
31	9582P-06012-00	BOLT, FLANGE	1	
32	95707-06500-00	NUT, FLANGE	1	
33	4LR-83371-00-00	HORN	1	