

**DID YOU
KNOW?**

CartPros directs you to the right part using the part numbers from this manual. Enter the part number into our search box and it will find the part you are looking for.

**GET STARTED
HERE** →

<https://CartPros.com/f.html>



A Textron Company

S E R V I C E P A R T S M A N U A L



605276

Electric Three Wheeled Vehicle

ISSUE DATE: JUNE 2006

 **CARTPROS**

**DID YOU
KNOW?**

CartPros directs you to the right part using the part numbers from this manual. Enter the part number into our search box and it will find the part you are looking for.

**GET STARTED
HERE**



<https://CartPros.com/f.html>

**DID YOU
KNOW?**

CartPros directs you to the right part using the part numbers from this manual. Enter the part number into our search box and it will find the part you are looking for.

**GET STARTED
HERE** →

<https://CartPros.com/f.html>

SERVICE PARTS MANUAL

ELECTRIC POWERED THREE WHEEL SERVICE VEHICLE

INDUSTRIAL 835™

STARTING MODEL YEAR: 2007

E-Z-GO Division of Textron Inc., reserves the right to make design changes without obligation to make these changes on units previously sold and the information contained in this manual is subject to change without notice.

E-Z-GO Division of Textron Inc., is not liable for errors in this manual or for incidental or consequential damages that result from the use of the material in this manual.

CUSTOMER SERVICE DEPARTMENT IN USA PHONE: 1-800-241-5855 FAX: 1-800-448-8124

OUTSIDE USA PHONE: 001-706-798-4311, FAX: 001-706-771-4609

E-Z-GO DIVISION OF TEXTRON, INC., P.O.BOX 388, AUGUSTA, GEORGIA USA 30906-3852

NOTES

To obtain a copy of the limited warranty applicable to the vehicle, call or write a local Distributor, authorized Branch or the Warranty Department with vehicle serial number and manufacturer code.

The use of non Original Equipment Manufacturer (OEM) parts may void the warranty.

Overfilling of batteries may void the warranty.

BATTERY PROLONGED STORAGE

All batteries will self discharge over time. The rate of self discharge varies depending on the ambient temperature and the age and condition of the batteries.

A fully charged battery will not freeze in winter temperatures unless the temperature falls below -75° F (-60° C).

As with all electric vehicles, the batteries must be checked and recharged as required or at a minimum of 30 day intervals.

TABLE OF CONTENTS

SECTION	Page No.
HOW TO USE THE SERVICE PARTS MANUAL	-v
ILLUSTRATED PARTS BREAKDOWN	-ix
BATTERY CHARGER	A-1
BODY & DECALS	B-1
BRAKE PEDAL & LINKAGE	C-1
DIFFERENTIAL	D-1
EE COMPONENTS	E-1
ELECTRICAL COMPONENTS	F-1
FORK, HUB & HANDLEBARS	G-1
FRONT & REAR WHEELS - TIRES	H-1
MOTOR	J-1
SEATING	K-1
SPEED CONTROL PEDAL	L-1
STEERING WHEEL ACCESSORY	M-1

HOW TO USE THE SERVICE PARTS MANUAL

This manual is divided into several sections:

GENERAL INFORMATION

- TABLE OF CONTENTS
- HOW TO USE THE SERVICE PARTS MANUAL

ILLUSTRATED PARTS BREAKDOWN

- Contains illustrations and parts lists for all systems of the vehicle.

USE OF THE MANUAL

To use this manual, consult the TABLE OF CONTENTS (page iii) to locate the information or illustration required.

Introduction of some revisions varies due to supply of components; therefore, it is possible that various combinations of components may be found that are not directly reflected by each illustration. Consult the illustration that best suits your situation. Locate the serial number plate (see BODY located in the Illustrated Parts Breakdown section of this manual for its location) and note the complete number shown on the plate. It is important that the serial number of your vehicle and its model number be supplied to Service Parts when ordering any replacement components.

HOW TO USE THE SERVICE PARTS MANUAL

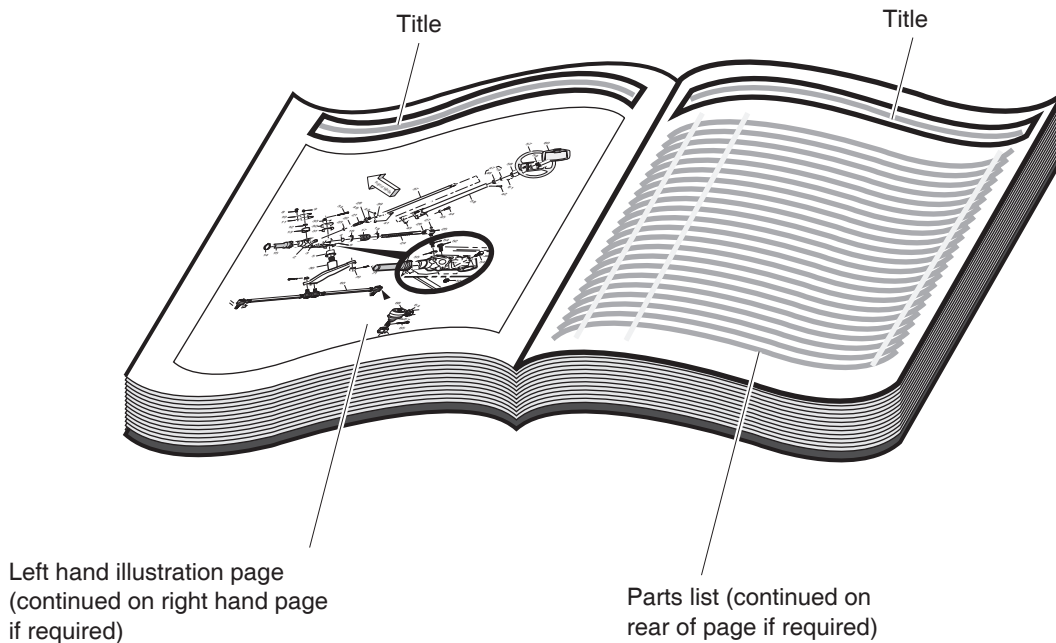

1. WHEN THE PART NUMBER IS NOT KNOWN

- Determine the function and application of the part required. Turn to the TABLE OF CONTENTS and select the most appropriate component description.
- Turn to the page number indicated and locate the part description in the parts list. Read the full accompanying description for specific information regarding the part that was not shown in the index.
- From the parts list, obtain the item number assigned to it and confirm that the part selected is correct by verifying it with the pictorial representation on the illustrated page.

Should an asterisk (*) appear in the part number column on the parts list page, read upwards until a part number is found. The part number is the lowest assembly sold by Service Parts. The asterisk (*) indicates that the part depicted is not available for purchase.

NOTE: Descriptions are indented under the assembly that they are used on. That assembly is, in turn listed under the assembly that it is used on. This process is repeated until the highest final assembly is reached.

To facilitate the maintenance and repair of the vehicle, a Technician's Repair and Service Manual is available from the Service Parts Department.

HOW TO USE THE SERVICE PARTS MANUAL

VEHICLE IDENTIFICATION

THESE IDENTIFICATION NUMBERS MUST APPEAR ON ALL CORRESPONDENCE CONCERNING THE VEHICLE.

VEHICLE MODEL NUMBER/

MODEL YEAR & SERIAL NUMBER

The vehicle model number decal is located on upper left portion of kick panel. The complete (10) ten digit number is required to identify certain parts.

The vehicle serial number is stamped on top of the frame adjacent to the Battery Compartment.



Model Number, Model Year and Serial Number on Decal

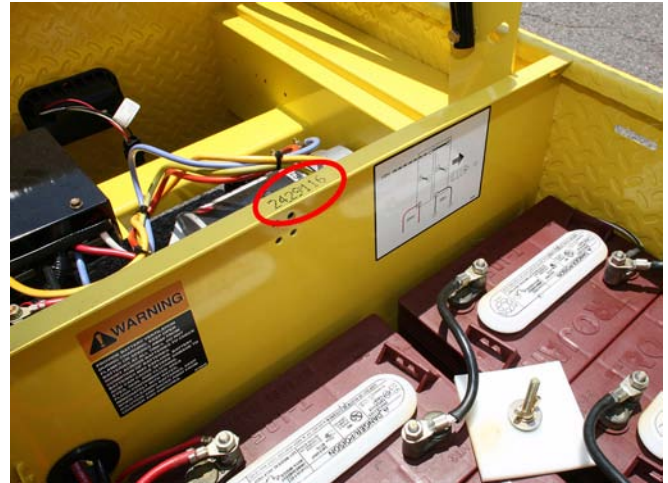

Vehicle Serial Number on the Frame Adjacent to the Battery Compartment

**DID YOU
KNOW?**

CartPros directs you to the right part using the part numbers from this manual. Enter the part number into our search box and it will find the part you are looking for.

**GET STARTED
HERE**



<https://CartPros.com/f.html>

ILLUSTRATED PARTS BREAKDOWN

ILLUSTRATED PARTS BREAKDOWN

BATTERY CHARGER

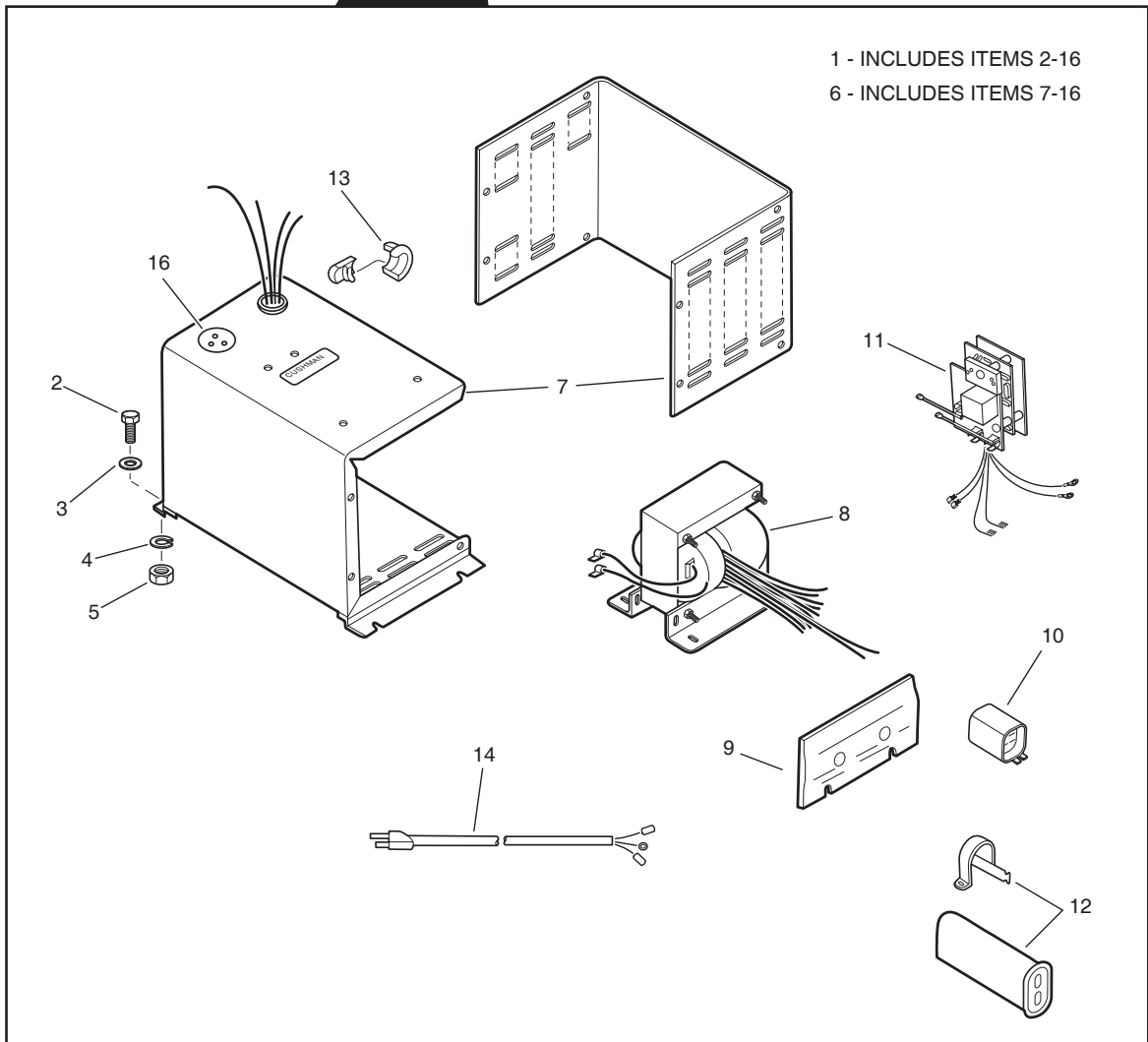
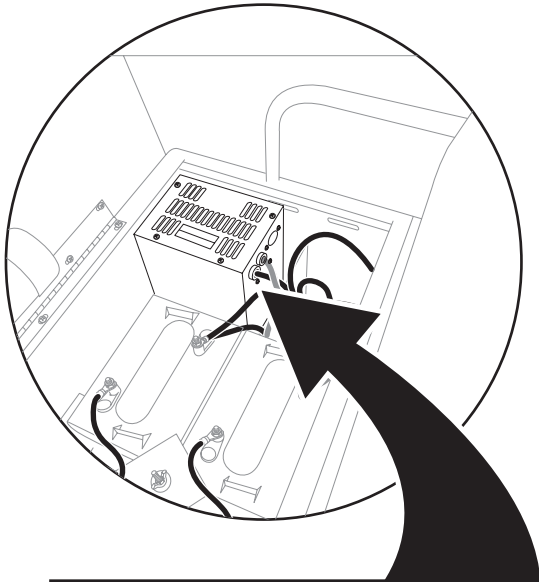

BATTERY CHARGER

Where applicable, THE USE OF NON UL PARTS WILL VOID ANY UL LISTING.
 When ordering parts, please specify the model and serial number of the product.
 * Indicates a component that is not available as an individual part.
 G** Indicates consult Customer Service Department for additional information.

ITEM	PART NO.	1 2 3 4 5	DESCRIPTION	QTY.
1	892860		LESTER MODEL 16940, 25 AMP, 115 VAC, 60 HZ (INCLUDES ITEMS 2-16)	
2	800017		SCREW, 1/4-20 X 1" LG	4
3	308090		WASHER, 1/4"	4
4	306396		LOCK WASHER, 1/4"	4
5	306375		NUT, 1/4-20	4
6	892860		CHARGER, COMPLETE, MODEL 16940 (INCLUDES ITEMS 7-16).....	1
7	892889		CASE, LESTER NO. 21559S	1
8	892890		TRANSFORMER, LESTER NO. 16945S	1
9	886435		HEATSINK, W/DIODES	1
10	892893		RELAY	1
11	892891		TIMER	1
12	823749		CAPACITOR, 6.0 MFD.....	1
13	822048		BUSHING, A.C. CORD	1
14	883216		CORDSET, A.C.....	1
15	892892		WIRING HARNESS (NOT ILLUSTRATED)	1
16	883844		FUSE.....	1

BODY & DECALS

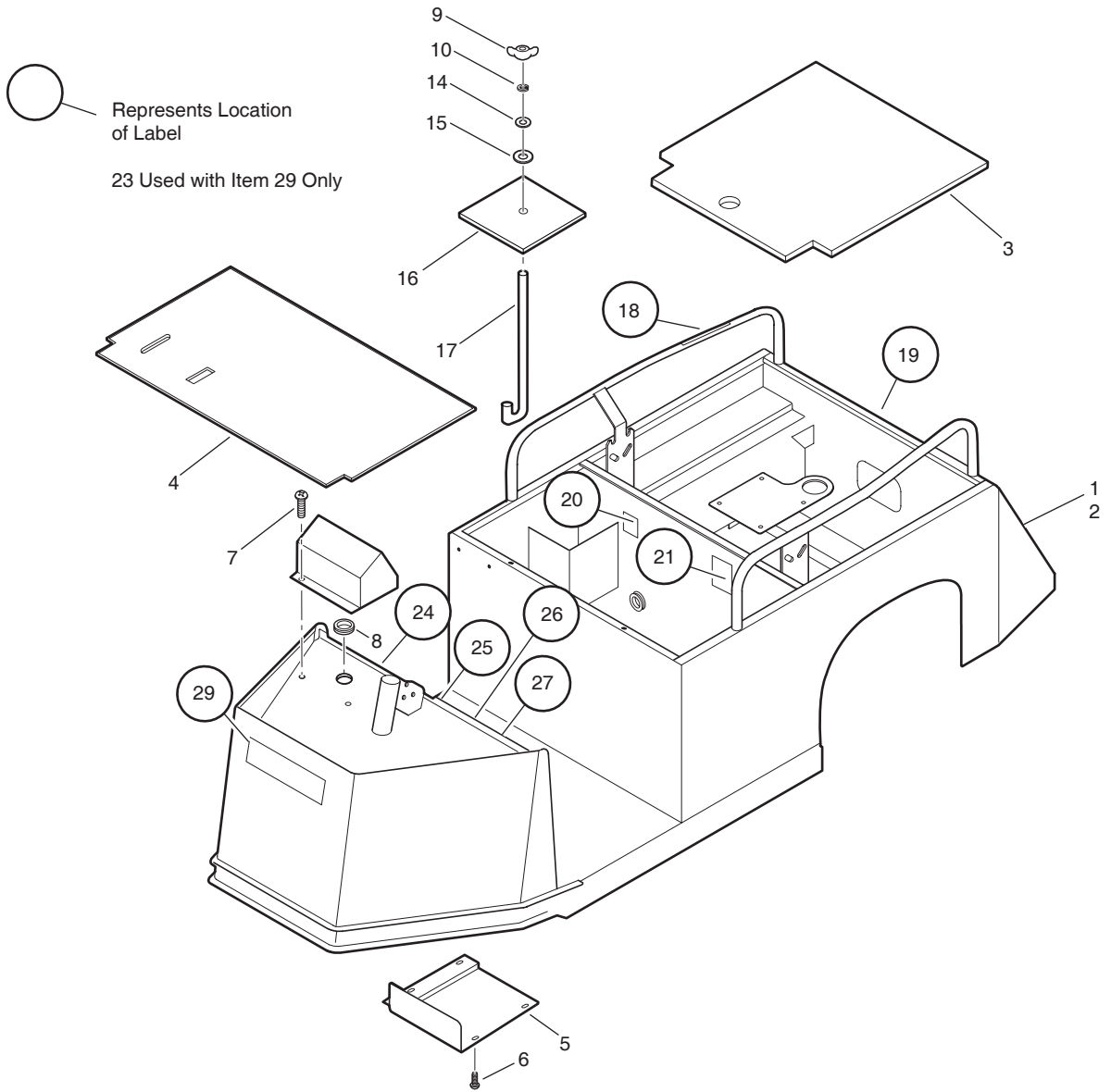



BODY & DECALS

WARNING

READ OPERATORS MANUAL BEFORE OPERATING CHARGER.
DO NOT CHARGE IN EXPLOSIVE ATMOSPHERE.
SPARKS MAY IGNITE BATTERY GAS (HYDROGEN).
2. PROTECT BATTERIES FROM SHORT CIRCUITING.
TO PREVENT ELECTRICAL SHOCK, DO NOT USE CHARGER COILS AND WHEELS IMMEDIATELY.

OPERATING INSTRUCTIONS

CONNECT CHARGER PLUG TO A GROUNDED RECEPTACLE WITH POWER RATINGS AS INDICATED ON CHARGER.
CHARGER WILL TURN ON AND SHUT OFF AUTOMATICALLY.
KEEP CHARGER VENTILATION OPENINGS CLEAR. POOR VENTILATION CAN DAMAGE CHARGER.
BATTERIES CHARGED IN UNHEATED AREAS (BELOW 65°F) SHOULD BE CHARGED AS SOON AFTER USE AS POSSIBLE.
CHARGE BATTERIES ONCE EACH WEEK FOR FOUR HOURS IN TEMPERATURE ABOVE 65 °F TO IMPROVE STATE OF CHARGE AND BATTERY LIFE.

832925

27

WARNING USE HAZD HODS

832925

18

WARNING

FAILURE TO READ THESE WARNINGS MAY RESULT IN PERSONAL INJURY OR DEATH. YOUR OWNERS MANUAL MAY ALSO RESULT IN EQUIPMENT AND/OR PROPERTY DAMAGES.

BEFORE OPERATING VEHICLE:
READ AND UNDERSTAND OPERATORS MANUAL (LOCATED UNDER SEAT).
ALL OCCUPANTS MUST BE SEATED IN FACTORY APPROVED SEATS.
NEVER OPERATE VEHICLE IN EXPLOSIVE OR COMBUSTIBLE ATMOSPHERE.

WHILE OPERATING VEHICLE:
KEEP BODY AND VEHICLE PASSENGER MUST BE SEATED AND USE HAND HOUS PROUDLY.
SUDDEN SHARP TURNS, UNBALANCED OR TOP HEAVY LOADS CAN CAUSE UPSET.
CARGO MUST BE SECURED TO PLATFORM.
NEVER OPERATE VEHICLE WITH PASSENGERS.
ADJUST SPEED TO YOUR SITUATION.

BEFORE LEAVING VEHICLE:
SET DIRECTION SELECTOR TO "OFF" POSITION.
TURN KEY TO VERTICAL "OFF" POSITION AND REMOVE.
NEVER LEAVE VEHICLE UNATTENDED.
WORK PERFORMED BY AUTHORIZED PERSONNEL.
APPLY HAND OR FOOT BRAKE. NOT AUTOMATICALLY APPLIED.

863387

24

WARNING

Failure to follow this warning can cause severe personal injury or death.

This vehicle is designed and intended for OFF-ROAD USE ONLY. Do not use on public roads, streets, highways, sidewalks, or other motor vehicles are present. Such use can be hazardous to the operator and other drivers, passengers or bystanders.

2316021

25

SERIAL NUMBER LABEL NOT SHOWN



29



19

WARNING

PROVIDE BATTERY VENTILATION TO PREVENT ACCUMULATION OF FLAMES OR SPARKS AWAY FROM BATTERIES AT ALL TIMES. DO NOT SHORT ACROSS BATTERIES TO CHECK BATTERY. BATTERY IS MAY EXPLODE. BATTERY ACID CAN CAUSE SEVERE DAMAGE TO SKIN AND EYES. IF ACID IS FLUSH CONTAMINATED AREA IMMEDIATELY WITH WATER. NEVER CLEANING BATTERIES. KEEP BATTERIES AWAY FROM CHARGER AND SWITCHES.

810938

20

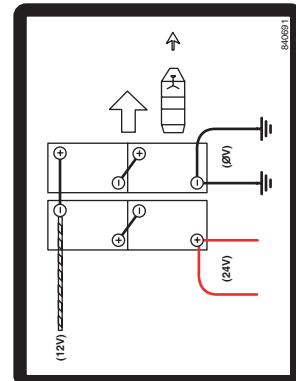

21

BODY & DECALS

Where applicable, THE USE OF NON UL PARTS WILL VOID ANY UL LISTING.
 When ordering parts, please specify the model and serial number of the product.
 * Indicates a component that is not available as an individual part.
 G** Indicates consult Customer Service Department for additional information.

ITEM	PART NO.	1 2 3 4 5	DESCRIPTION	QTY.
1	892709		BODY, W/DECALS	1
2	893187		BODY, GALVANIZED W/DECALS.....	1
3	840684		DECK, CARGO AREA	1
4	840528		MAT, FLOOR	1
5	840770		GUARD, PEDAL.....	1
6	800026		SCREW, 1/4-20 X 3/4" LG	4
7	548013		SCREW, 1/4-20 X 1/2" LG	2
8	828247		GROMMET.....	2
9	800315		NUT, WING 5/16-18	1
10	306325		LOCK WASHER, 5/16".....	1
11				
12				
13				
14	809152		WASHER, 5/16"	3
15	818303		WASHER, REBOUND BUMPER	1
16	840695		PLATE, BATTERY HOLD DOWN	1
17	806954		BOLT, BATTERY HOLD DOWN	1
18	825328		LABEL, WARNING, USE HAND HOLDS.....	2
19	840696		LABEL, WARNING, NO STANDING.....	1
20	819936		LABEL, WARNING, BATTERY VENTILATION.....	1
21	840691		LABEL, BATTERY WIRING	1
22				
23	12064-G3		PUSH NUT, 3/16"	3
24	825387		LABEL, WARNING, VEHICLE OPERATION	1
25	29165		LABEL, NOTICE, OFF-HIGHWAY	1
26	*		SERIAL NUMBER LABEL.....	1
27	830926		LABEL, WARNING, CHARGER OPERATION.....	1
28				
29	71037-G02		E-Z-GO NAMEPLATE	1

BRAKE PEDAL & LINKAGE

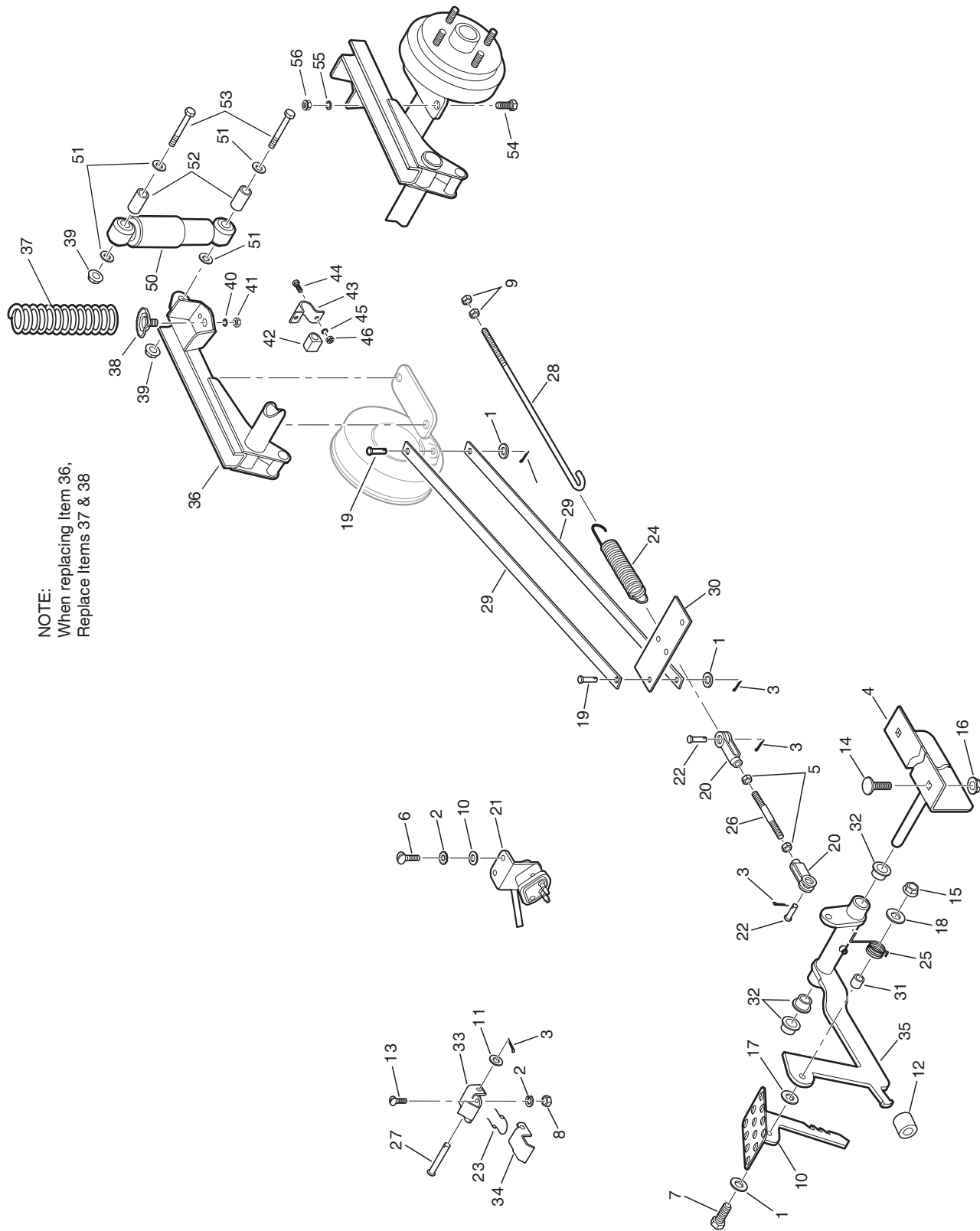

BRAKE PEDAL & LINKAGE

Where applicable, THE USE OF NON UL PARTS WILL VOID ANY UL LISTING.
 When ordering parts, please specify the model and serial number of the product.
 * Indicates a component that is not available as an individual part.
 G** Indicates consult Customer Service Department for additional information.

ITEM	PART NO.	1 2 3 4 5	DESCRIPTION	QTY.
1	103867		WASHER, 11/32"	4
2	120052		LOCK WASHER, #10.....	4
3	306328		PIN, COTTER 3/32 X 3/4" LG	7
4	2703903.7		PIVOT, BRAKE	1
5	306320		NUT, 5/16-24.....	2
6	306391		SCREW, #10-32 X 5/16" LG	2
7	306435		SCREW, 5/16-18 X 1 1/4" LG	1
8	306531		NUT, #10-24.....	2
9	306932		NUT, 5/16-18.....	2
10	892802		LATCH, BRAKE	1
11	308090		WASHER, 1/4"	1
12	517163		SPACER.....	1
13	800271		SCREW, #10-24 X 1/2" LG	2
14	800557		BOLT, CARRIAGE 5/16-18 X 3/4" LG.....	2
15	800290		NUT, LOCK 5/16-18	1
16	800697		NUT, FLANGELOCK 5/16-18.....	2
17	800873		WASHER, NYLON 3/8"	1
18	800874		WASHER, 11/32"	2
19	806714		PIN, CLEVIS 5/16 X 15/16" LG	4
20	810722		YOKE	2
21	814005		SWITCH	1
22	806703		PIN, CLEVIS.....	2
23	817507		SPRING.....	1
24	822313		SPRING, EXTENSION.....	1
25	829860		SPRING.....	1
26	830661		ROD, THREADED.....	1
27	830784		PIN, PIVOT.....	1
28	831861		BOLT, ADJUSTING.....	1
29	840326		STRAP, BRAKE	4
30	840335		CROSSMEMBER, BRAKE.....	1

BRAKE PEDAL & LINKAGE

Where applicable, THE USE OF NON UL PARTS WILL VOID ANY UL LISTING.
 When ordering parts, please specify the model and serial number of the product.
 * Indicates a component that is not available as an individual part.
 G** Indicates consult Customer Service Department for additional information.

ITEM	PART NO.	1 2 3 4 5	DESCRIPTION	QTY.
31	840491		BUSHING	1
32	840494		BEARING, FLANGED	3
33	840666		LATCH, BRAKE LOCK.....	1
34	840667		LATCH, PARK BRAKE.....	1
35	2703900.7		ARM, BRAKE	1
36	897151		FRAME, POWER	1
37	805437		SPRING.....	2
38	876660		RETAINER	2
39	800294		NUT, LOCK 7/16-14	2
40	809152		WASHER, 5/16"	3
41	308332		NUT, 1/2-13.....	2
42	816667		BLOCK, STABILZER.....	2
43	825366		RETAINER	2
44	306835		SCREW, 3/8-16 X 1 1/4" LG	4
45	120177		LOCK WASHER, 3/8".....	4
46	306562		NUT, 3/8-16.....	4
47				
48				
49				
50	807332		SHOCK ABSORBER.....	1
51	825500		WASHER, CUPPED.....	4
52	823621		BUSHING	2
53	311396		SCREW, 7/16-14 X 2" LG	2
54	800546		SCREW, M12-1.25 X 35MM LG.....	4
55	120166		LOCK WASHER, 1/2".....	6
56	800875		NUT, M12-1.25.....	4

DIFFERENTIAL

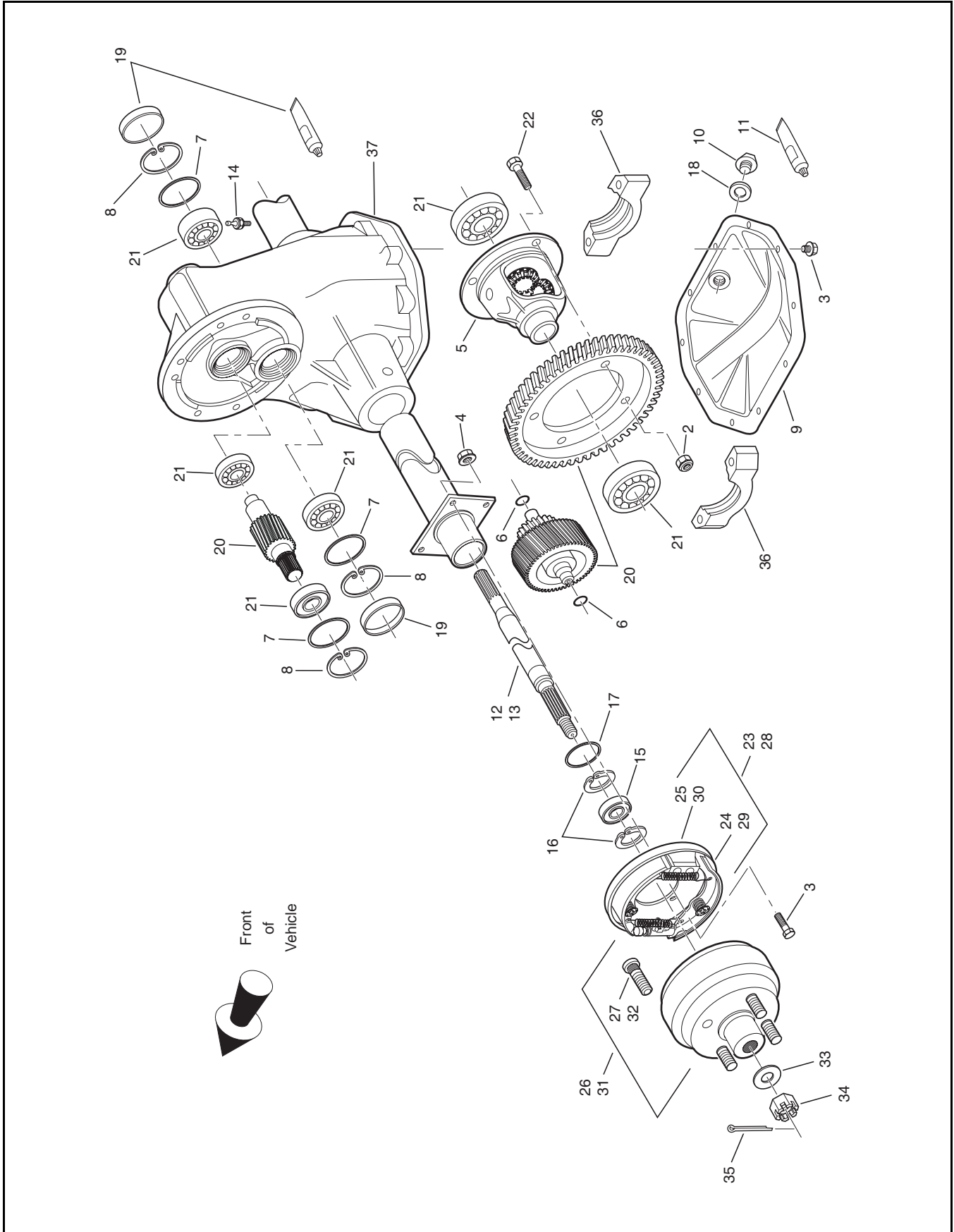

DIFFERENTIAL

Where applicable, THE USE OF NON UL PARTS WILL VOID ANY UL LISTING.

When ordering parts, please specify the model and serial number of the product.

* Indicates a component that is not available as an individual part.

G** Indicates consult Customer Service Department for additional information.

ITEM	PART NO.	1 2 3 4 5	DESCRIPTION	QTY.
1	4115147		DIFFERENTIAL, COMPLETE (INCLUDES ITEMS 1-31)	
2	306319		NUT, 3/8-24	4
3	306450		SCREW, 5/16-18 X 3/4" LG	18
4	548911		NUT, FLANGELOCK 5/16-18	8
5	840807		CASE ASSEMBLY	1
6	840808		SEAL, O-RING	2
7	840809		SEAL, O-RING	3
8	840810		RING, RETAINING	3
9	4115172		COVER, CARRIER	1
10	845316		PLUG, FILL (HEX HEAD)	1
11			SEAL, COVER PLATE	1
12	840814		SHAFT, AXLE LH	1
13	840815		SHAFT, AXLE RH	1
14	840816		VENT	1
15	840817		BEARING	2
16	840818		RING, RETAINING	4
17	840819		SEAL, OIL	2
18	840820		WASHER, FLAT PLASTIC	1
19	840821		KIT, INTERMEDIATE SEAL	1
20	840822		GEAR SET	1
21	840823		KIT, CARRIER BEARING	1
22	840824		SCREW, 3/8-24 X 1 1/8" LG	4
23	4115155		BRAKE, (LEFT), COMPLETE (INCLUDES ITEMS 24-25)	1
24	4115170		KIT, BRAKE SHOES (1 WHEEL)	2
25	892968		KIT, BRAKE HARDWARE (1 WHEEL)	2
26	892969		HUB, W/ STUDS (INCLUDES ITEM 27)	2
27	840844		STUD, WHEEL MOUNTING	4
28	4115156		BRAKE, (RIGHT), COMPLETE (INCLUDES ITEMS 29-30)	1
29	892866		KIT, BRAKE SHOES (1 WHEEL)	2
30	892968		KIT, BRAKE HARDWARE (1 WHEEL)	2

DIFFERENTIAL

Where applicable, THE USE OF NON UL PARTS WILL VOID ANY UL LISTING.

When ordering parts, please specify the model and serial number of the product.

* Indicates a component that is not available as an individual part.

G** Indicates consult Customer Service Department for additional information.

ITEM	PART NO.	1 2 3 4 5	DESCRIPTION	QTY.
31	892969		HUB, W/ STUDS (INCLUDES ITEM 32).....	2
32	840844		STUD, WHEEL MOUNTING	4
33	850017		WASHER.....	2
34	500389-7		CASTLE NUT	2
35	500024-6		COTTER PIN.....	2
36	*		CLAMP, BOTTOM.....	2
37	*		CASING, UPPER	1

EE COMPONENTS

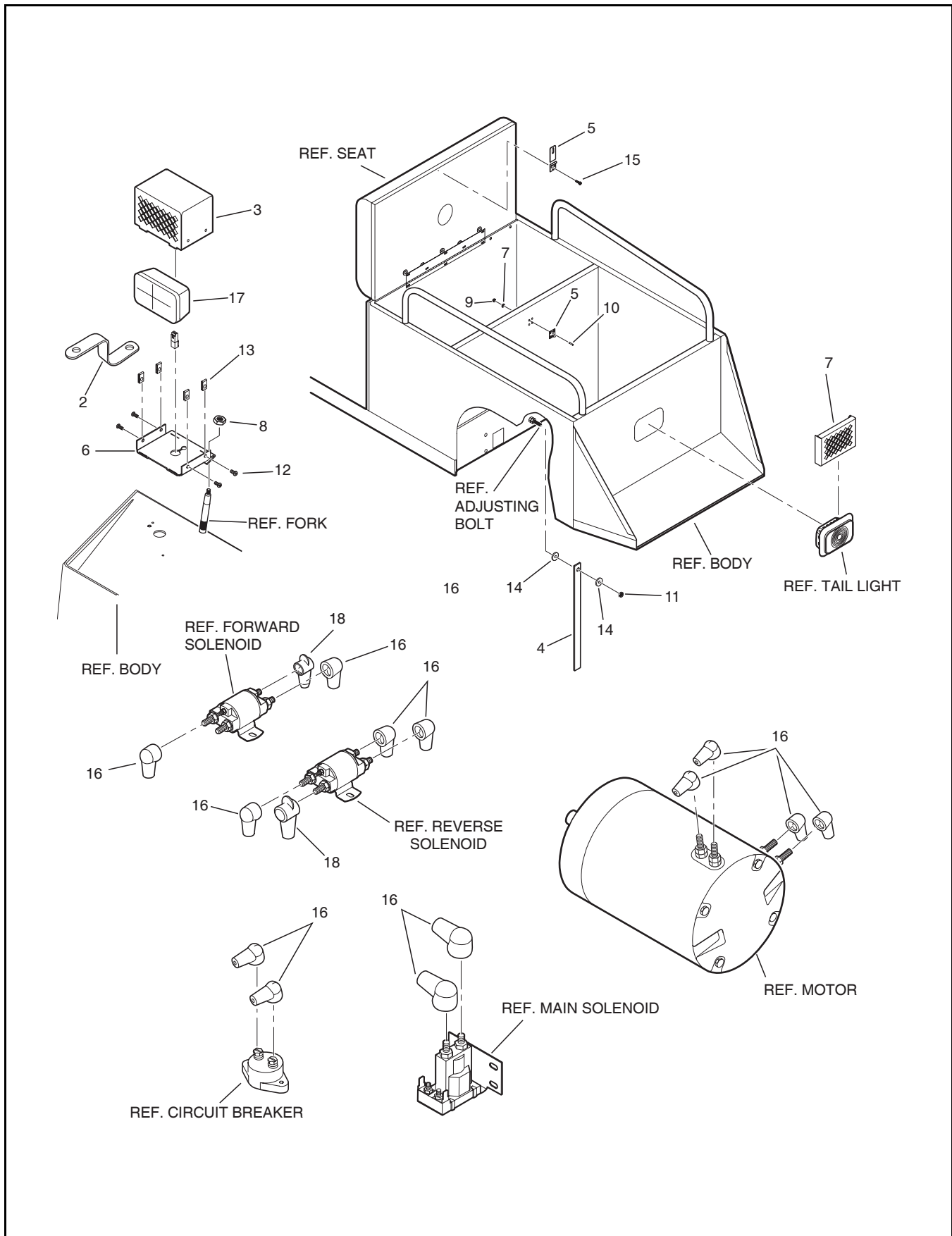

EE COMPONENTS

Where applicable, THE USE OF NON UL PARTS WILL VOID ANY UL LISTING.
 When ordering parts, please specify the model and serial number of the product.
 * Indicates a component that is not available as an individual part.
 G** Indicates consult Customer Service Department for additional information.

ITEM	PART NO.	1 2 3 4 5	DESCRIPTION	QTY.
1	120052		LOCK WASHER, #10".....	4
2	840854-G01		BRACKET	1
3	2702875.7		COVER, HEADLIGHT GUARD	1
4	2702915		STRAP, STATIC.....	1
5	2702994		HASP, SAFETY W/STAPLE	1
6	2703038.7		BASE, HEADLIGHT GUARD	1
7	2703039.7		COVER, REAR LIGHT	1
8	305134		NUT, 7/8-14, JAM.....	1
9	306531		NUT, #10-24.....	4
10	306532		SCREW, #10-24 X 5/8" LG	4
11	306932		NUT, 5/16-18.....	1
12	800019		SCREW, 1/4-29 X 1/2" LG	4
13	800238		NUT, 1/4-20, SPEED.....	4
14	800874		WASHER, 11/32"	2
15	800965		SCREW, 12-14 X 3/4" LG,	3
16	844328		BOOT, TERMINAL	13
17	892523		HEADLIGHT.....	1
18	840177		BOOT, TERMINAL.....	2

ELECTRICAL COMPONENTS

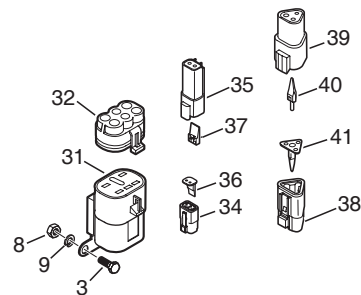
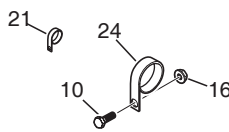
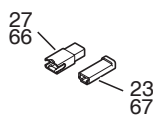
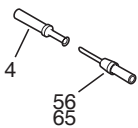
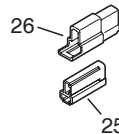
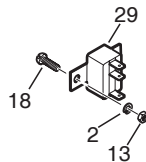
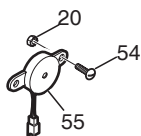
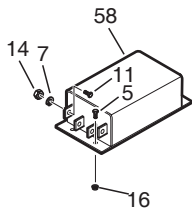
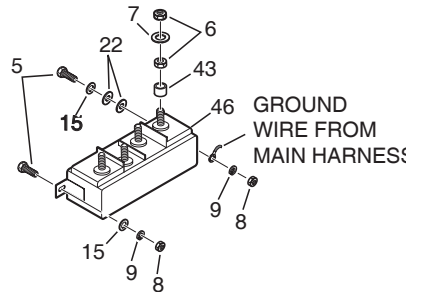
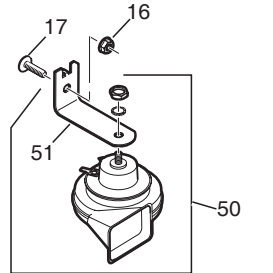
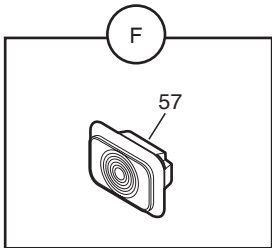
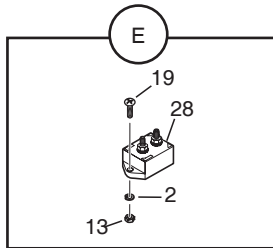
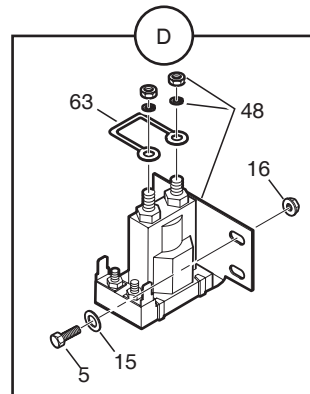
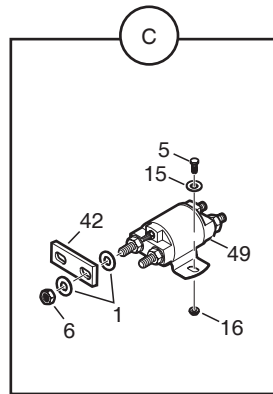
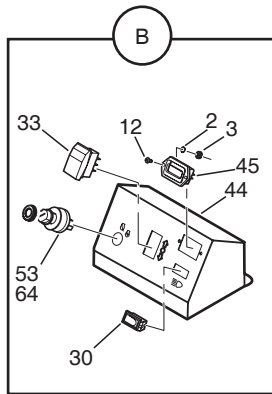
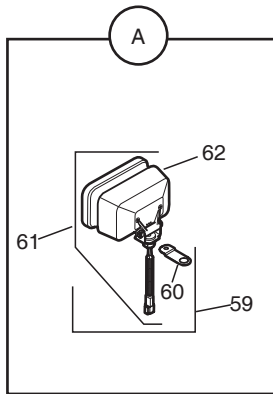
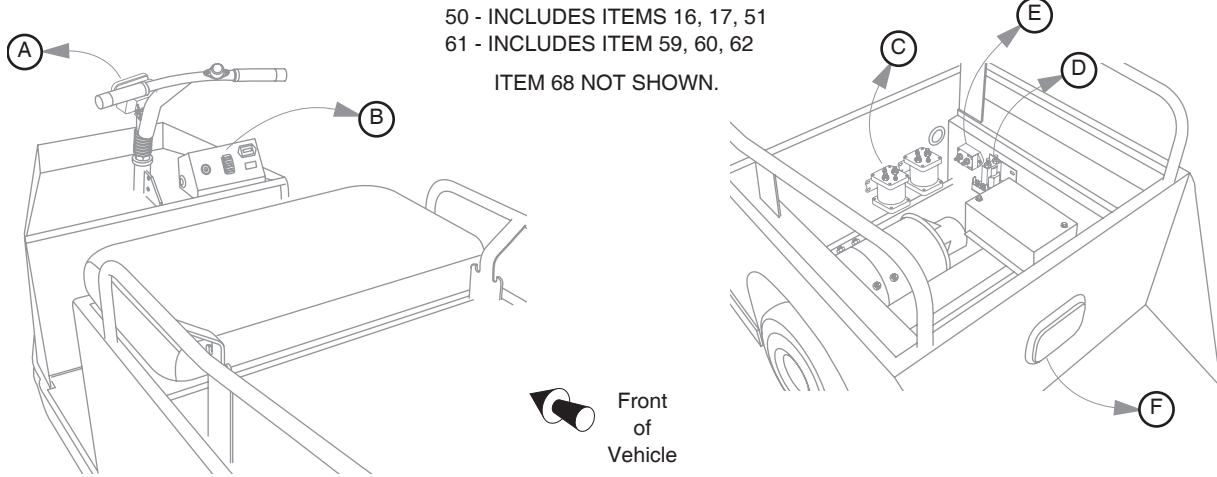

ELECTRICAL COMPONENTS

Where applicable, THE USE OF NON UL PARTS WILL VOID ANY UL LISTING.
 When ordering parts, please specify the model and serial number of the product.
 * Indicates a component that is not available as an individual part.
 G** Indicates consult Customer Service Department for additional information.

ITEM	PART NO.	1 2 3 4 5	DESCRIPTION	QTY.
1	103867		WASHER, 5/16"	8
2	120052		WASHER, #10.....	7
3	300646		SCREW, 1/4-20 X 3/4" LG	2
4	838769		TERMINAL, SOCKET	AR
5	302288		SCREW, 1/4-20 X 1" LG	14
6	306320		NUT, 5/16-24.....	12
7	306325		LOCK WASHER, 5/16".....	8
8	306375		NUT, 1/4-20.....	8
9	306396		LOCK WASHER, 1/4".....	7
10	306419		SCREW, 1/4-20 X 1/2" LG	1
11	306450		SCREW, 5/16-18 X 3/4" LG	4
12	306514		SCREW, #10-24 X 1/2" LG	2
13	306531		NUT, #10-24.....	7
14	306932		NUT, 5/16-18.....	4
15	308090		WASHER, 1/4"	8
16	548910		NUT, 1/4-20 FLANGELOCK.....	12
17	800017		SCREW, 1/4-20 X 1" LG	1
18	800271		SCREW, #10-24 X 1/2" LG	2
19	800299		SCREW, #10-24 X 1" LG	3
20	800587		NUT, #4-40 W/LOCK WASHER.....	2
21	814924		CLAMP	3
22	817719		BUSHING, FIBER	2
23	825880		CONNECTOR, 1 CONTACT PLUG	AR
24	825884		CLAMP	1
25	826005		CONNECTOR, 2 CONTACT PLUG	AR
26	826006		CONNECTOR, 2 CONTACT RECEPTACLE.....	AR
27	826726		CONNECTOR, 1 CONTACT RECEPTACLE.....	AR
28	829164		CIRCUIT BREAKER, 90 AMP.....	1
29	829780		CIRCUIT BREAKER, 20 AMP.....	1
30	830640		SWITCH, ROCKER.....	1

ELECTRICAL COMPONENTS

Where applicable, THE USE OF NON UL PARTS WILL VOID ANY UL LISTING.

When ordering parts, please specify the model and serial number of the product.

* Indicates a component that is not available as an individual part.

G** Indicates consult Customer Service Department for additional information.

ITEM	PART NO.	1 2 3 4 5	DESCRIPTION	QTY.
31				
32				
33	836354		SWITCH	1
34	839917		PLUG, 2-WIRE	AR
35	839918		RECEPTACLE, 2-WIRE	AR
36	839921		LOCK, 2-WIRE PLUG	AR
37	839935		LOCK, 2-WIRE RECEPTACLE	AR
38	839849		PLUG, 3-WIRE	AR
39	839850		RECEPTACLE, 3-WIRE	AR
40	840117		LOCK, 3-WIRE RECEPTACLE	AR
41	840118		LOCK, 3-WIRE PLUG	AR
42	840273		BAR, SOLENOID BUS	2
43	840491		BUSHING	4
44	840496		PANEL, CONTROL	1
45	840526		GAUGE, BATTERY CONDITION.....	1
46				
47	840679		RECTIFIER BRIDGE.....	1
48	841208		SOLENOID, 24 VOLT, MAIN CONTACT	1
49	841248		SOLENOID, 24 VOLT	2
50	886425		HORN (INCLUDES ITEM 51).....	1
51	829694		BRACKET, HORN	1
52	880631		HOUR METER SET (ACCESSORY)	1
53	886311		SWITCH, IGNITION	1
54	888503		SERVICE SET CONTAINS TWO #4-40 X 3/4" L SCREWS	1
55	890000		BUZZER	1
56	524358		TERMINAL, MALE PIN (16-18 GAUGE).....	AR
57	892676		LIGHT, RED (TAIL LIGHT).....	1
58	4110440		CONTROLLER, SPEED.....	1
59	892942		HEADLIGHT SET (ACCESSORY) (INCLUDES ITEMS 60-62)	1
60	840854		BRACKET, HEADLIGHT	1

ELECTRICAL COMPONENTS

Where applicable, THE USE OF NON UL PARTS WILL VOID ANY UL LISTING.
 When ordering parts, please specify the model and serial number of the product.
 * Indicates a component that is not available as an individual part.
 G** Indicates consult Customer Service Department for additional information.

ITEM	PART NO.	1 2 3 4 5	DESCRIPTION	QTY.
61	892523		HEADLIGHT (INCLUDES ITEM 62)	1
62	840860		BULB, HEADLIGHT	1
63	893142		RESISTOR, 250 OHM.....	1
64	886311		SWITCH, IGNITION, KEYED ALIKE	1
65	840676		TERMINAL, MALE PIN (14-16 GAUGE).....	AR
66	825886		TERMINAL, 1/4 FEMALE, 14-16AWG	AR
67	825748		TERMINAL, 1/4 FEMALE, 14-16AWG	AR
68	7035		GREASE, ELECTRICAL CONNECTOR.....	1



FORK, HUB & HANDLEBARS

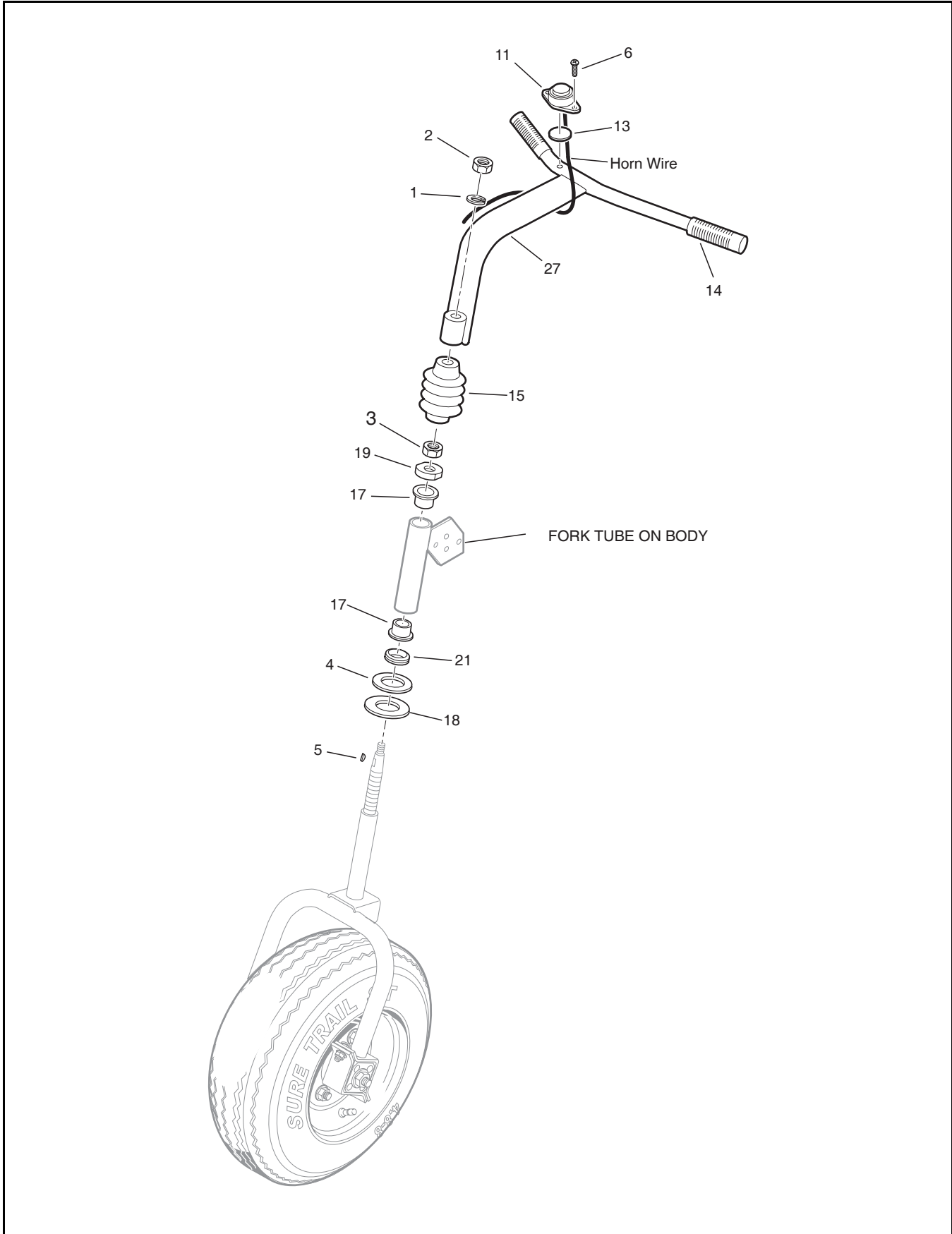

FORK, HUB & HANDLEBARS

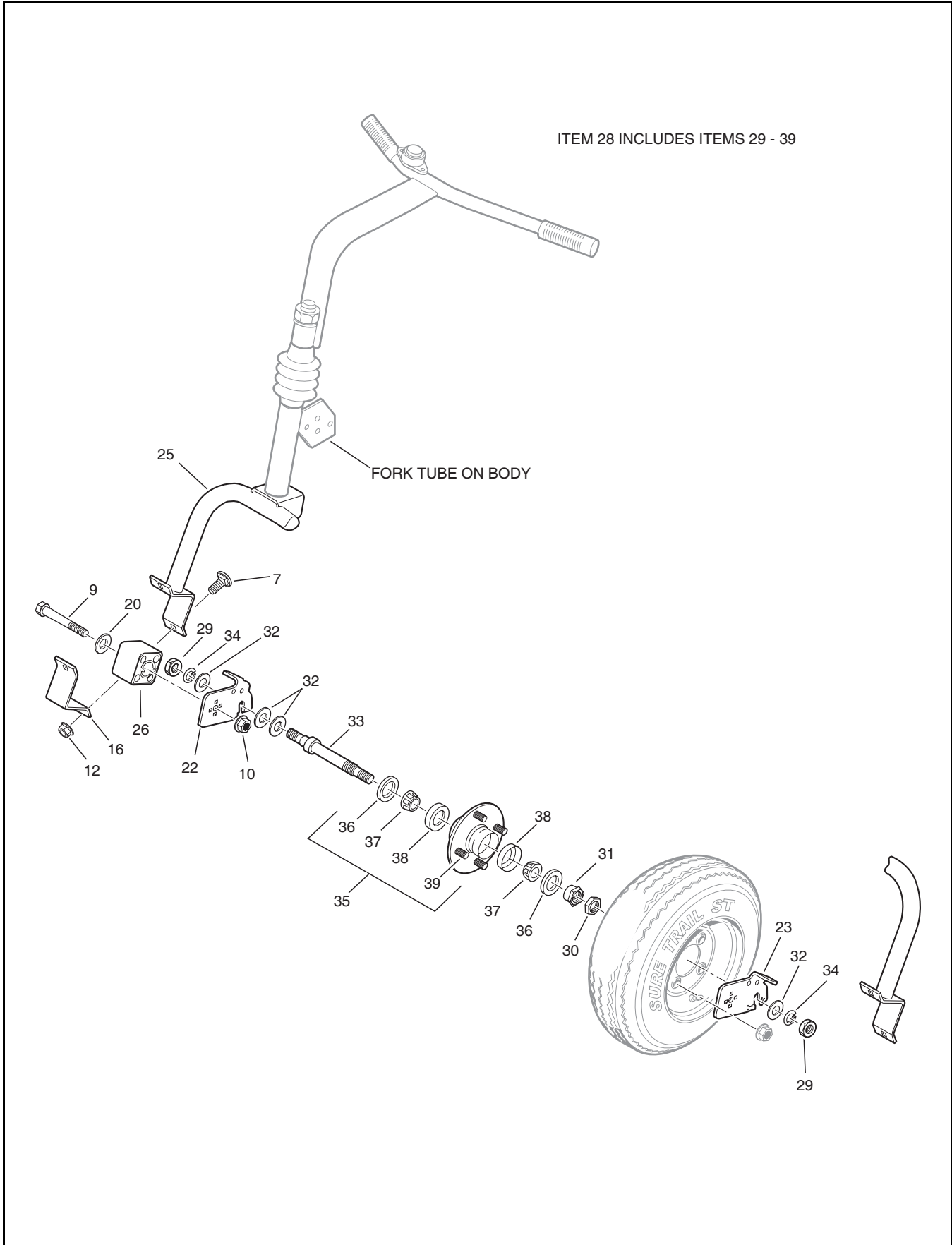

FORK, HUB & HANDLEBARS

Where applicable, THE USE OF NON UL PARTS WILL VOID ANY UL LISTING.
 When ordering parts, please specify the model and serial number of the product.
 * Indicates a component that is not available as an individual part.
 G** Indicates consult Customer Service Department for additional information.

ITEM	PART NO.	1 2 3 4 5	DESCRIPTION	QTY.
1	120166		LOCK WASHER, 1/2".....	1
2	301988		NUT, 1/2-20.....	1
3	305134		NUT, JAM 7/8-14.....	2
4	520231		WASHER, THRUST 1 1/4".....	1
5	551041		KEY, WOODRUFF #6.....	1
6	800144		SCREW, #10-16 X 5/8" LG.....	2
7	800500		BOLT, CARRIAGE 3/8-16 X 1" LG.....	4
8				
9	800610		SCREW, FLANGE 7/16-20 X 1 1/8" LG.....	2
10	800612		NUT, LOCK 7/16-20.....	2
11	806791		HORN BUTTON.....	1
12	800698		NUT, FLANGELOCK 3/8-16.....	4
13	807290		INSULATOR, HORN.....	1
14	807472		GRIP, HANDLE.....	2
15	831909		BOOT.....	1
16	840318		CLAMP, HALF.....	2
17	840318		BEARING, FLANGED.....	2
18	840372		WASHER, RUBBER.....	1
19	840411		NUT, SPINDLE.....	1
20	840412		WASHER, 7/16".....	2
21	840479		RING, V.....	1
22	840479		BRACKET, FORK RH.....	1
23	840689		BRACKET, FORK LH.....	1
24				
25	892701		FORK.....	1
26	892744		MOUNT, SUSPENSION.....	2
27	892764		HANDLE BAR.....	1
28	892781		AXLE & HUB ASSEMBLY (INCLUDES ITEMS 29-39).....	1
29	130084		NUT, 5/8-18.....	2
30	310854		NUT, JAM 1-14.....	1

FORK, HUB & HANDLEBARS

Where applicable, THE USE OF NON UL PARTS WILL VOID ANY UL LISTING.
 When ordering parts, please specify the model and serial number of the product.
 * Indicates a component that is not available as an individual part.
 G** Indicates consult Customer Service Department for additional information.

ITEM	PART NO.	1	2	3	4	5	DESCRIPTION	QTY.
31	815814						NUT, BEARING ADJUSTING	1
32	809156						WASHER, THRUST 9/16"	4
33	840325						AXLE	1
34	306494						LOCK WASHER, 5/8"	2
35	892781						HUB ASSEMBLY (INCLUDES ITEMS 36-39)	1
36	700290						SEAL, GREASE	2
37	814473						BEARING	2
38	814474						RACE, BEARING	2
39	843616						BOLT, WHEEL	4

FRONT & REAR WHEELS - TIRES

1 INCLUDES ITEMS 2-4

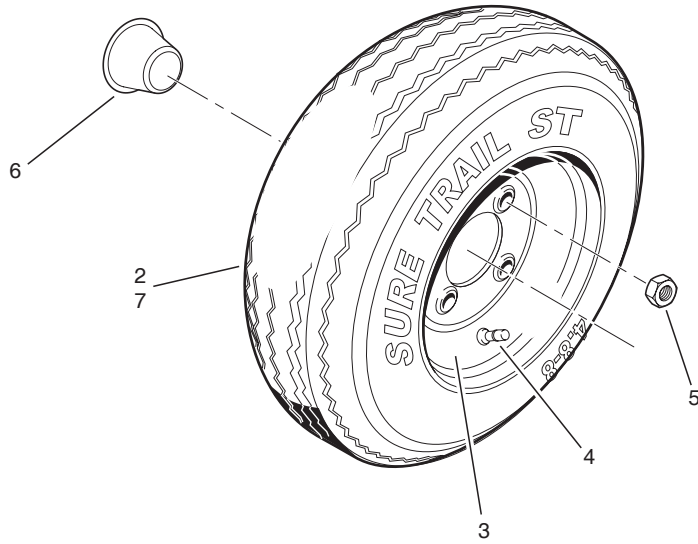

FRONT & REAR WHEELS - TIRES

Where applicable, THE USE OF NON UL PARTS WILL VOID ANY UL LISTING.
 When ordering parts, please specify the model and serial number of the product.
 * Indicates a component that is not available as an individual part.
 G** Indicates consult Customer Service Department for additional information.

ITEM	PART NO.	1	2	3	4	5	DESCRIPTION	QTY.
1	600424						TIRE AND WHEEL, SOLID TIRE, SET OF 3 (INCLUDES ITEMS 2-4)	1
2	602494						TIRE	1
3	33678						RIM	1
4	886735						VALVE STEM	1
5	14723G01						LUG NUT 1/2-20	1
6	74175G01						DUST COVER	1
7	600450						TIRE & WHEEL ASSEMBLY (FOAM FILLED) (INCLUDES ITEMS 2-4)	1

MOTOR

1 - Includes Items 3 - 12

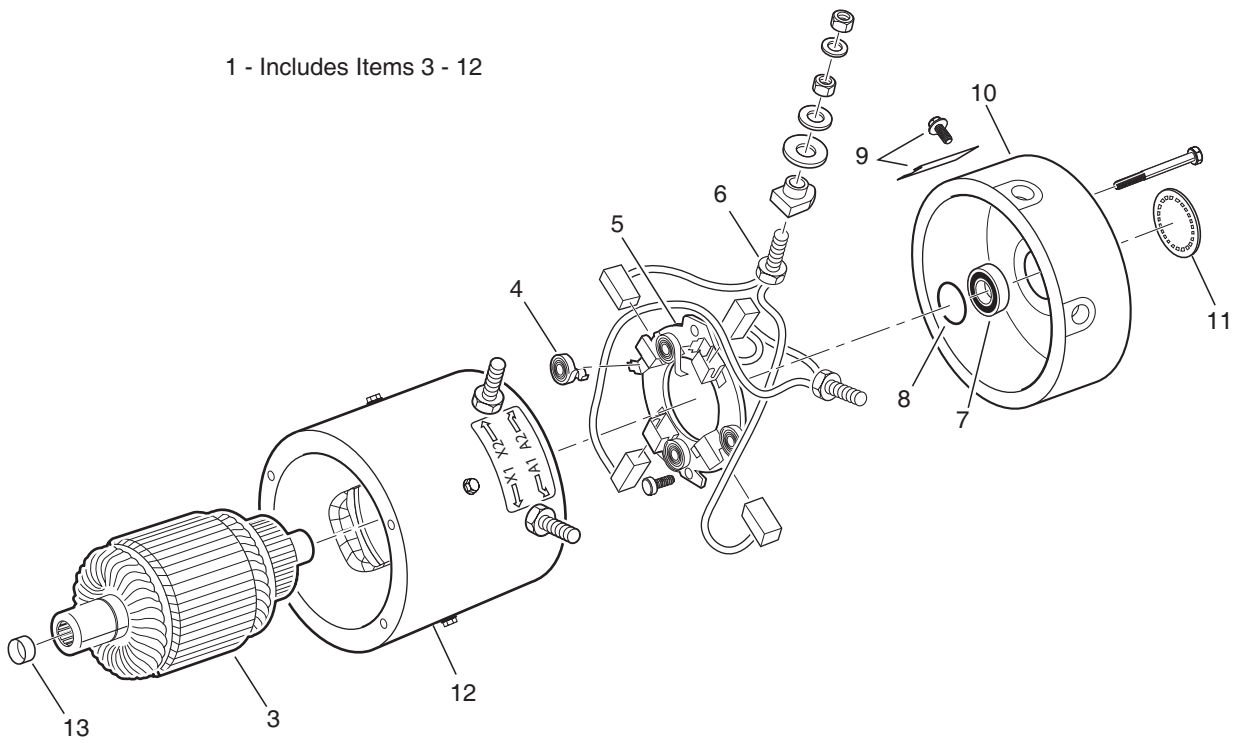

MOTOR

Where applicable, THE USE OF NON UL PARTS WILL VOID ANY UL LISTING.
 When ordering parts, please specify the model and serial number of the product.
 * Indicates a component that is not available as an individual part.
 G** Indicates consult Customer Service Department for additional information.

ITEM	PART NO.	1 2 3 4 5	DESCRIPTION	QTY.
1	73445G01		MOTOR, SERIES (INCLUDES ITEMS 3-12)	1
2				
3	73120-G01		ARMATURE	1
4	73120-G03		BRUSH SPRING.....	4
5	73120-G15		BRUSH PLATE AND BOX.....	1
6	73120-G25		BRUSH REPLACEMENT KIT (INCLUDES HARDWARE)	1
7	73120-G07		BEARING	1
8	73120-G06		SNAP RING	1
9	73120-G09		COVER PLATE AND SCREW.....	1
10	73120-G08		COMMUTATOR END HOUSING	1
11	73120-G16		CAP.....	1
12	73120-G31		FRAME AND FIELD COIL (G02 MOTOR) (INCLUDES HARDWARE)	1
13	24261-G1		SPLINE BUMPER	1

SEATING

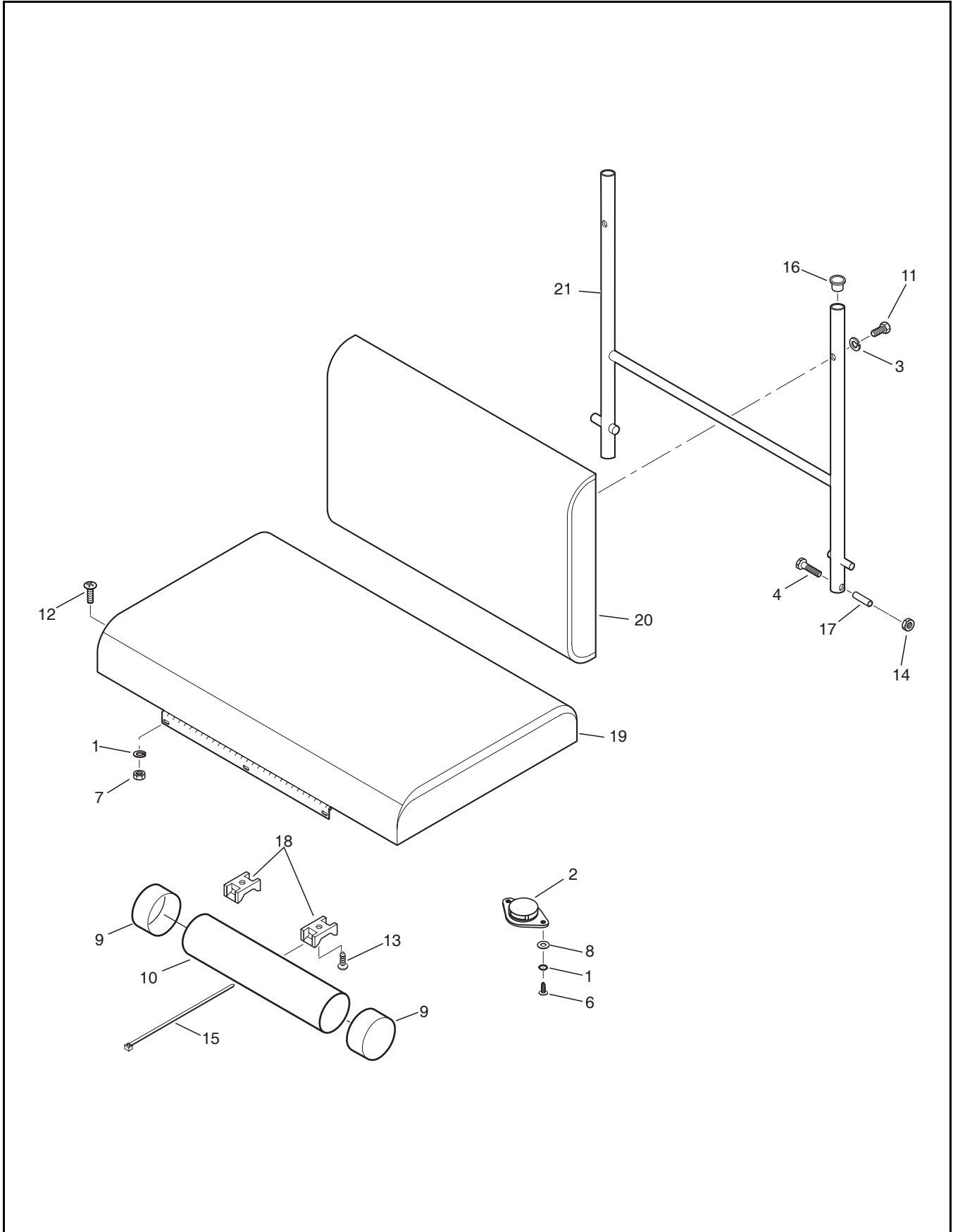

SEATING

Where applicable, THE USE OF NON UL PARTS WILL VOID ANY UL LISTING.
 When ordering parts, please specify the model and serial number of the product.
 * Indicates a component that is not available as an individual part.
 G** Indicates consult Customer Service Department for additional information.

ITEM	PART NO.	1 2 3 4 5	DESCRIPTION	QTY.
1	120052		LOCK WASHER, #10".....	5
2	158135-01		SWITCH, SEAT.....	1
3	306396		LOCK WASHER, 1/4".....	3
4	306423		SCREW, 5/16-18 X 1 3/4" LG.....	2
5				
6	306527		SCREW, #10-24 X 3/4" LG.....	2
7	306531		NUT, #10-24.....	3
8	308089		WASHER, #10".....	2
9	38061A		CAP, VINYL.....	2
10	38541		TUBE, DOCUMENT.....	1
11	600014		SCREW, 1/4-20 X 1 3/4" LG.....	4
12	800271		SCREW, #10-24 X 1/2" LG.....	3
13	800344		SCREW, #10-16 X 9/16" L TAPPING.....	2
14	800697		NUT, FLANGELOCK 5/16-18.....	2
15	823549		TIE, WIRE 15.5" (40MM).....	2
16	826747		PLUG, HOLE.....	2
17	840499		BUSHING.....	2
18	840508		MOUNT, CABLE TIE.....	2
19	883938		SEAT.....	1
20	884683		BACKREST.....	1
21	892823		FRAME, BACKREST.....	1

SPEED CONTROL PEDAL

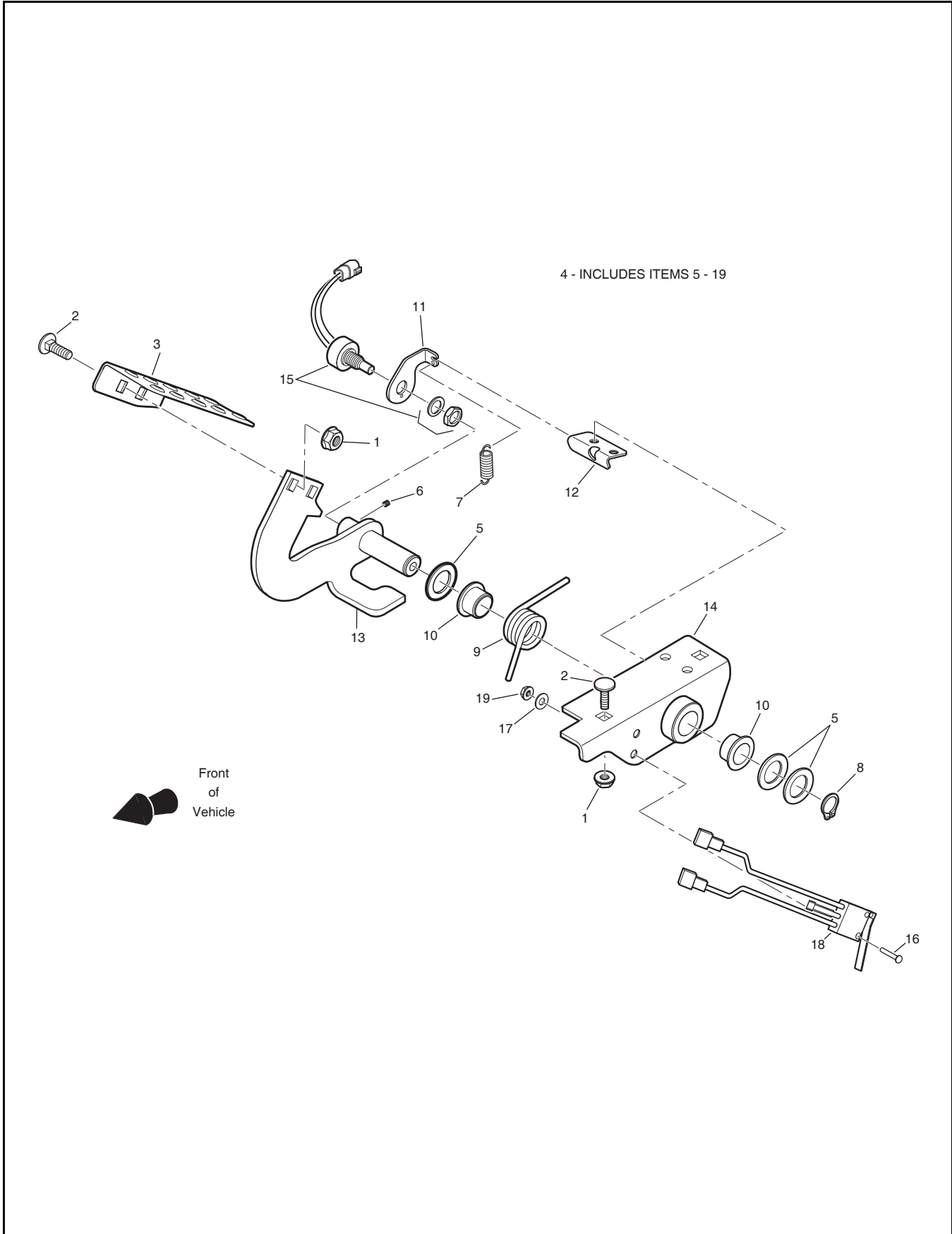

SPEED CONTROL PEDAL

Where applicable, THE USE OF NON UL PARTS WILL VOID ANY UL LISTING.
 When ordering parts, please specify the model and serial number of the product.
 * Indicates a component that is not available as an individual part.
 G** Indicates consult Customer Service Department for additional information.

ITEM	PART NO.	1 2 3 4 5	DESCRIPTION	QTY.
1	548911		NUT, FLANGELOCK, 5/16-18.....	4
2	800557		BOLT, CARRIAGE, 5/16-18 X 3/4" LG.....	4
3	840419		PEDAL, SPEED CONTROL.....	1
4	897184		SPEED CONTROL ASSEMBLY (INCLUDES ITEMS 5-19)	1
5	548478		WASHER, FLAT	3
6	800225		SCREW, SET, #10-24 X 1/4" LG	1
7	805421		SPRING, INDEX	1
8	833104		RING, RETAINING	1
9	840435		SPRING, TORSION.....	1
10	840494		BEARING, FLANGED.....	2
11	869184		BRACKET, POTENTIOMETER MOUNT.....	1
12	840688		TAB.....	1
13	897184		ARM, SPEED CONTROL	1
14	897183		BRACKET, SPEED CONTROL MOUNT	1
15	4119768		POTENTIOMETER, 30°.....	1
16	800439		SCREW, #4-40 X 3/4" LG	2
17	308089		WASHER, FLAT	2
18	894439		SWITCH, NC.....	1
19	800587		NUT, #4-40	2

STEERING WHEEL ACCESSORY

1 - includes items 1 to 45
41 - includes items 42 to 43
35 - includes item 36

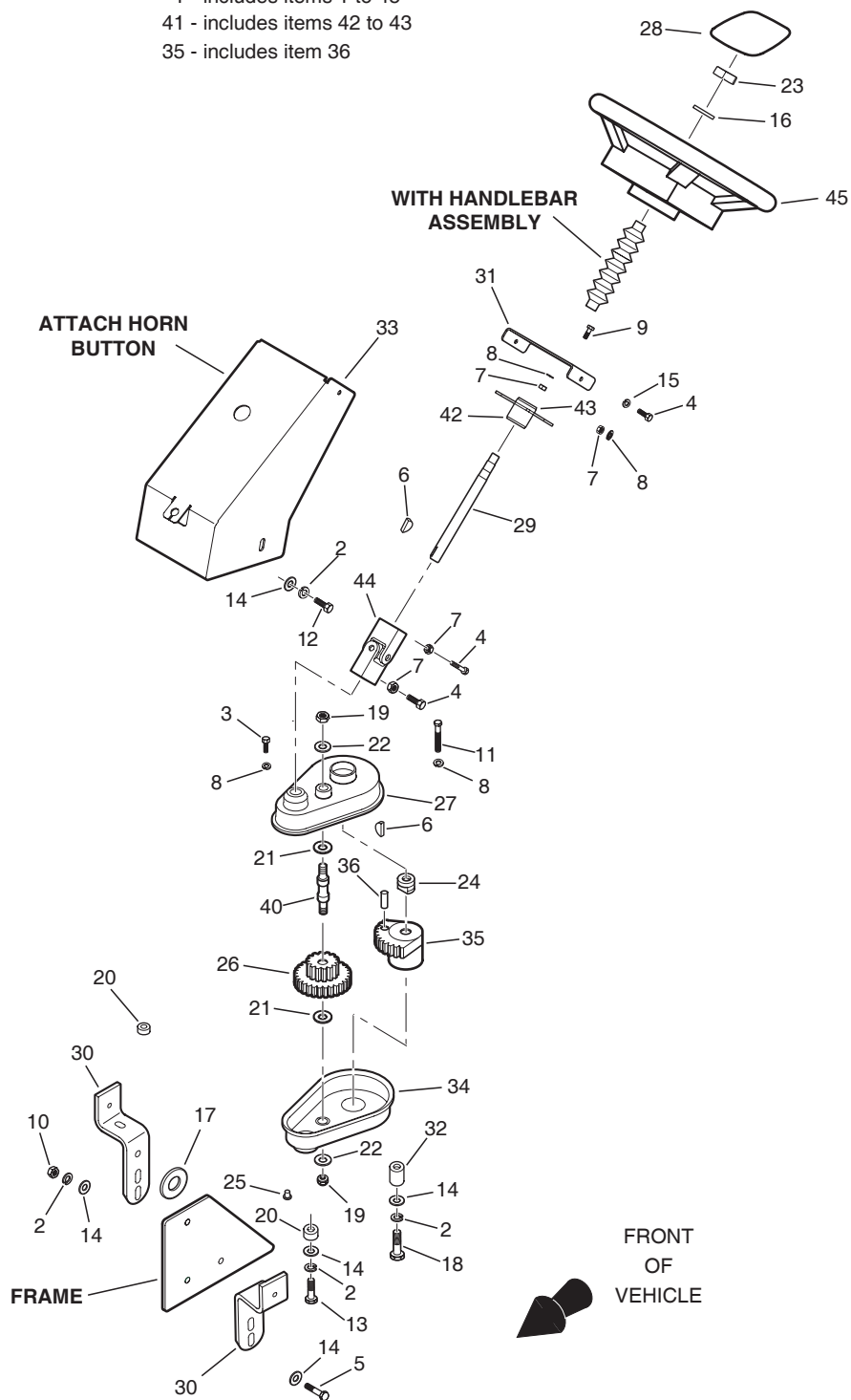

STEERING WHEEL ACCESSORY

Where applicable, THE USE OF NON UL PARTS WILL VOID ANY UL LISTING.
 When ordering parts, please specify the model and serial number of the product.
 * Indicates a component that is not available as an individual part.
 G** Indicates consult Customer Service Department for additional information.

ITEM	PART NO.	1	2	3	4	5	DESCRIPTION	QTY.
1	893079						ACCESSORY STEERING WHEEL (INCLUDES ITEMS 2-45).....	1
2	120177						LOCK WASHER, 3/8"	8
3	302030						SCREW, 1/4-20 X 1 1/4" LG.....	3
4	302288						SCREW, 1/4-20 X 1" LG.....	4
5	302600						SCREW, 3/8-16 X 1 1/2" LG.....	3
6	306367						KEY WOODRUFF .188 X .750" LG.....	2
7	306375						NUT, 1/4-20	8
8	306396						LOCK WASHER, 1/4"	11
9	306487						SCREW, 1/4-20 X .62" LG.....	4
10	306562						NUT, 3/8-16	3
11	306832						SCREW 1/4-20 X 2" LG.....	4
12	306834						SCREW 3/8-16 X 3/4" LG.....	2
13	306835						SCREW 3/8-16 X 1 1/4" LG.....	2
14	306981						WASHER, 3/8"	11
15	308090						WASHER, 1/4"	2
16	311496						WASHER, 5/8"	1
17	517663						WASHER.....	1
18	551094						SCREW, 3/6-16 X 1 3/4" LG.....	1
19	800612						NUT, 7/16 CROWN LOCK.....	2
20	808935						SPACER.....	2
21	816446						WASHER.....	2
22	816449						WASHER, LOCATING.....	2
23	816652						NUT, STEERING WHEEL.....	1
24	825672						NUT.....	1
25	825919						PLUG, HOLE.....	1
26	830168						GEAR, CLUSTER.....	1
27	832555						HOUSING, UPPER.....	1
28	892228						COVER, STEERING WHEEL CENTER.....	1
29	840981						SHAFT, STEERING WHEEL.....	1
30	840982						SUPPORT, STEERING.....	2

STEERING WHEEL ACCESSORY

Where applicable, THE USE OF NON UL PARTS WILL VOID ANY UL LISTING.
 When ordering parts, please specify the model and serial number of the product.
 * Indicates a component that is not available as an individual part.
 G** Indicates consult Customer Service Department for additional information.

ITEM	PART NO.	1	2	3	4	5	DESCRIPTION	QTY.
31	844264						PLATE, WHEEL MOUNT.....	1
32	844290						BUSHING.....	1
33	844292						COVER, STEERING.....	1
34	886883						HOUSING, LOWER.....	1
35	886913						GEAR ASSY, DRIVEN (INCLUDES ITEM 36)	1
36	310546						PIN, ROLL 1/2 X 1 1/2" LG.....	1
37								
38								
39								
40	883317						BOLT, IDLER ADJUSTING.....	1
41	891597						BUSHING ASSY, STEERING (INCLUDES ITEMS 42-43).....	1
42	548225						FITTING, LUBE	1
43	827188						BEARING	1
44	891680						JOINT ASSY, UNIVERSAL.....	1
45	892228						WHEEL, STEERING 14"	1

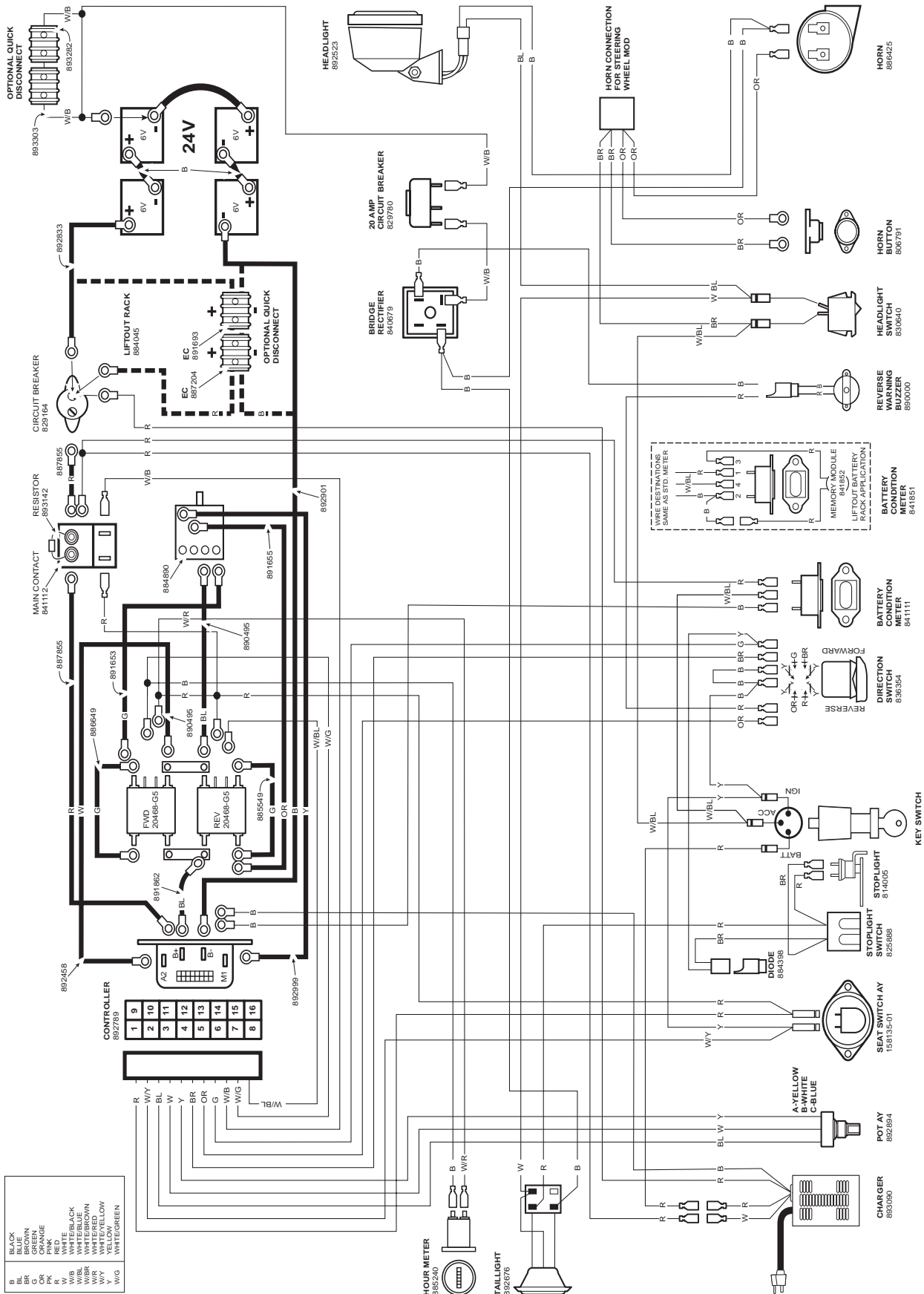

ALL WIRING IN MAIN HARNESS 897160 UNLESS NOTED

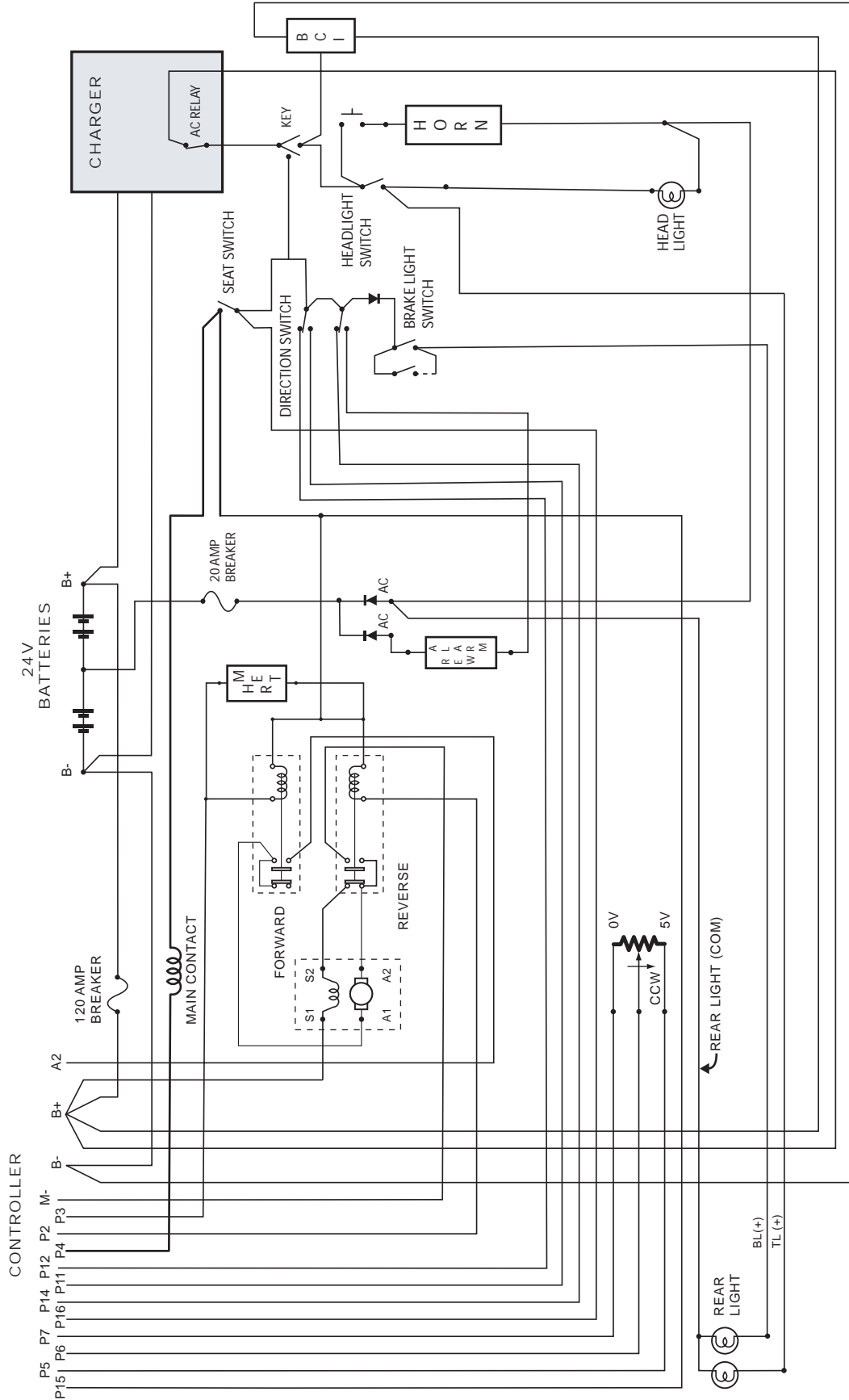

**DID YOU
KNOW?**

CartPros directs you to the right part using the part numbers from this manual. Enter the part number into our search box and it will find the part you are looking for.

**GET STARTED
HERE**



<https://CartPros.com/f.html>

**DID YOU
KNOW?**

CartPros directs you to the right part using the part numbers from this manual. Enter the part number into our search box and it will find the part you are looking for.

**GET STARTED
HERE** →

<https://CartPros.com/f.html>



A Textron Company



E-Z-GO Division of Textron, Inc.,
1451 Marvin Griffin Road, Augusta, Georgia USA 30906-3852

TO CONTACT US...

North America:

**Technical Assistance & Warranty
Service Parts**

Phone: 1-800-774-3946, FAX: 1-800-448-8124

Phone: 1-888-GET-E-Z-GO (1-888-438-3946), FAX: 1-800-752-6175

International:

Phone: 001-706-798-4311, FAX: 001-706-771-4609

Certified ISO 9001 / ISO 14001 by



Copyrighted Material
This manual may not be reproduced in whole or
in part without the express permission of
E-Z-GO Division of Textron, Inc.
Technical Communications Department